

HAKKIMIZDA; KALİTE POLİTİKAMIZ

HISTORY, OUR QUALITY POLICY



Tuma Hassas Tutucu Takımlar Medikal Otomotiv Makina San. Tic. Ltd. Şti. olarak 2000 yılında TUMA markası ile hassas tutucu takım ve CNC takım tezgahları için takım ve yedek parça üretimine başladık.

Hiçbir başarının tesadüflere dayalı olmadığını bilincinde olan hepimiz gibi, bizlerde siz değerli müşterilerimize, en iyiyi en uyguna sunabilmek için alanında uzman bir kadro ile gece-gündüz aralıksız olarak çalıştık.

Hidrolik Aynalar, Pnömatik Aynalar, Hidrolik Ayna Ayakları, Hidrolik Ayna Flanşları, Ünlversal Ayna Flanşları, CNC Torna Çubuk Çekicileri, CNC Torna Takım tutucuları, CNC Dik Torna Takımları, Makine Mengeneleri, Hassas Döner Puntalar, Şapkaklı Döner Puntalar, Hassas Boru Puntaları, Sabit Puntalar, CNC Torna Redüksiyon Kovanları, Özel Tutucu Takımlar ve Bağlama Sistemlerini titiz ve özverili bir çalışma ile kaliteli hammadde ve kaliteli makineler kullanılarak, kalite güvence birimlerinin onayından geçtikten sonra sizlerin beğenisine sunuyoruz.

Avrupa standartlarında üretim ve satış yapan TUMA ileriye dönük olarak yurt içinde olduğu gibi yurt dışı pazarında da bir marka olma yolunda hızla ilerlemektedir.

Sürekli gelişme ve başarıyı amaçlayan bir takım ruhu ile sektörde gelişen teknoloji paralelinde kaliteli ve kusursuz bir hizmet anlayışı ilkemizle, sizlerden aldığımız pozitif eleştirilerle kısa zamanda performansımızı artırarak ülke çapına bir marka olduk.

Çağın gereksinimi olan teknolojik gelişmeyi takip ederek, bilgisayar destekli tasarımlarla çalışmalarımıza dün olduğu gibi yarında en iyisi olmak için sürekli olarak devam edeceğiz.

SAYGILARIMIZLA...

We started production of spare parts for workholding tools and CNC lathes with TUMA brand as Tuma Hassas Tutucu Takımlar Medikal Otomotiv Makina San. Tic. Ltd. Şti. Like all who are aware of none kind of success is coincidence, we have worked all day-night without stopping to produce best quality products with most competitive price for our precious customers with personnels who are expersts in their fields;

We serve our products, Hydraulic Chucks, Pneumatic Chucks, Hydraulic Chucks Jaws, Hydraulic Chucks Flanges, Universal Chucks Flanges, CNC Lathe Bar Pullers, CNC Lathe Workholding Tools, CNC Vertical Lathe Tools, Machine Vices, Precision Rotary Centers, Precision Capped Centers, Precision Pipe Centers, Fixed Centers, CNC Lathe Reduction Hives, Special Workholding Tools and Connection Systems, to your admiration after they are confirmed by our quality control department, which we produced with maticiluous and selfless working by using quality raw materials and machines. TUMA which makes production and sales at European standards is on the way of being a known brand in overseas market as in local market. We became a locally known brand in a short time with a team aming continuous improving and success by keeping up pace with improving technology in our sector, with quality and excellent service principle, by increasing our performance with your positive criticisms.

We will always continue our works in future as in the past for being the best all the time by keeping up pace with the needed technology of our century with designs made in computers.

BEST REGARDS



İÇİNDEKİLER

Index



HİDROLİK AYNALAR	4	HYDRAULIC CHUCKS	4
HİDROLİK AYNA PARÇALARI	9	HYDRAULIC CHUCKS SPARE PARTS	9
ÜNİVERSAL AYNALAR	16	UNIVERSAL CHUCKS	16
ÜNİVERSAL AYNA PARÇALARI	21	UNIVERSAL CHUCKS SPARE PARTS	21
HASSAS DÖNER PUNTALAR	26	PRECISION ROTARY CENTERS	26
MAKİNA MENGENELERİ	45	MACHINE VICES	45
CNC TORNA ÇUBUK ÇEKİCİ	46	CNC LATHE BAR PULLERS	46
REDÜKSİYON KOVANI	47	HIVE REDUCTIONS	47
SABİT PUNTALAR	49	FIXED LATHE CENTERS	49
MANDREN MORS KONIĞI	56	MANDREN MORSE CONIC	56
MORS KOVANLARI	57	MORSE HIVES	57

INDEX

HİDROLİK
AYNALAR



TUMA[®]
HASSAS TUTUCU TAKIMLAR



**HYDRAULIC
CHUCKS**



Devir Sayısı - Sıkma Kuvveti
Speed - Gripping Force Diagram

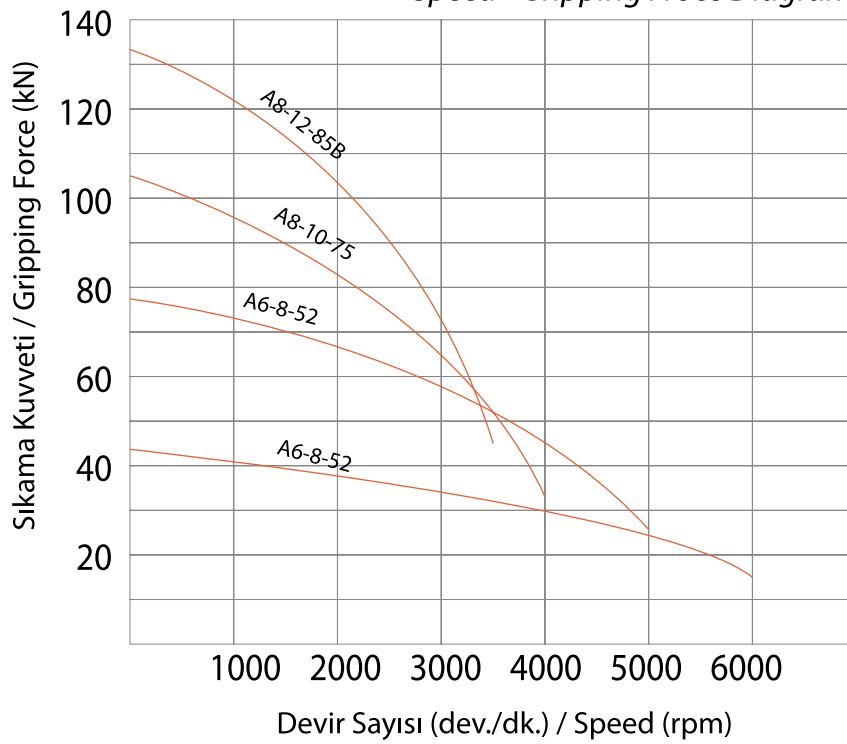

3 AYAKLI AÇIK MERKEZ HİDROLİK AYNALAR

3 JAWS HIGH SPEED OPEN-CENTER HYDRAULIC CHUCKS

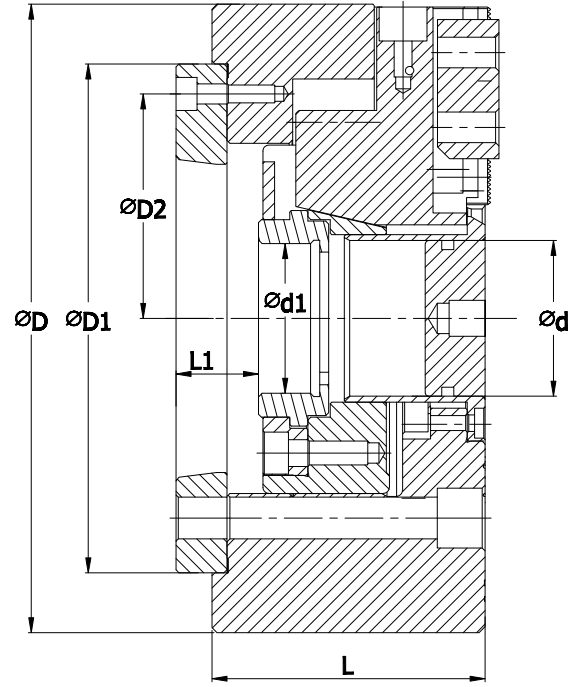
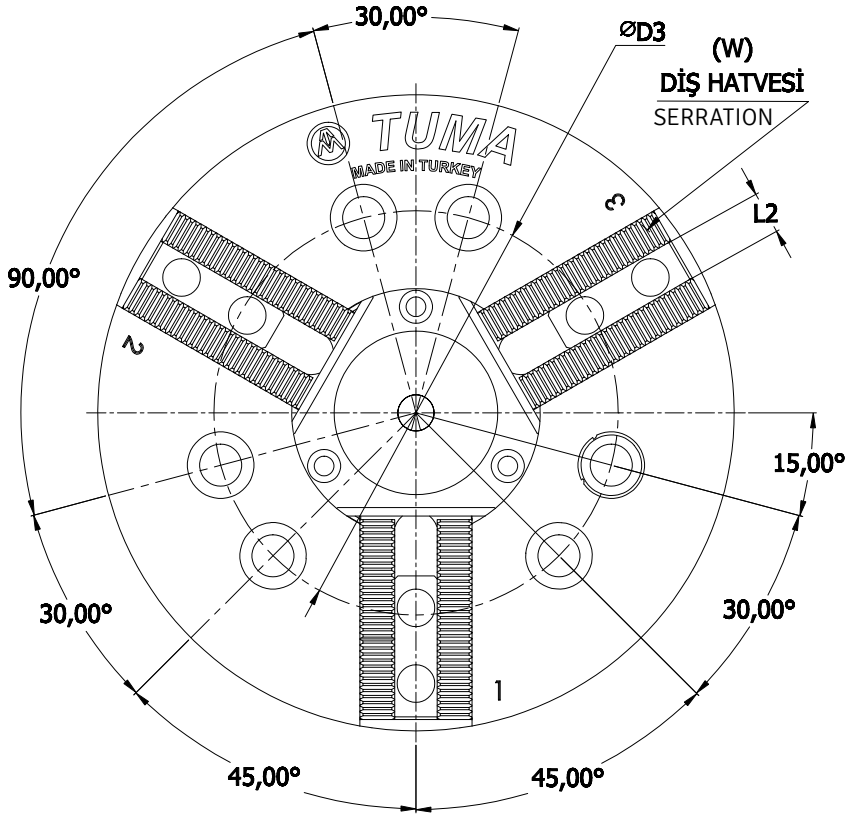

TR

THA geniş strok yüksek hız, 3 ayaklı tipler.

- Taban ayak dişleri 1.5 x 60° ve 3mm x 60°
- Standart bağlama ISO-A
- Hareketli parçalar alaşımı çeliktan imal edilmiş, sertleştirilmiş ve taşlanmıştır.
- 3 ayaklı modelleri mevcuttur.
- Standart aksesuarları: Bağlantı civata ve somunları

EN

THA large stroke, high speed, 3 jaws versions.

- Serration 1.5 x 60° and 3mm x 60°
- Standard mounting ISO-A
- All parts are made of alloyed steel, hardened and grinded
- 3 jaws chucks are available
- Standard accessories: Mounting bolts and nuts

TEKNİK ÖLÇÜLER (mm) / Technical Dimensions

Sipariş Kodu Order Code	Ayna Ebadı Chucks Size	D	D1	D2	D3	d	d1	L	L1	L2	W
THA-06	6"	169	140	r58	104.80	45	M50X2	81	14	12	1,5X60
THA-08	8"	210	170	r75	133,4	52	M60X2	91.25	15,5	14	1,5X60
THA-10	10"	254	220	r95	171,4	75	M78X2	100,2	18	16	1,5X60
THA-12	12"	304	220	r95	171,4	91	M100X2	110	20,5	21	1,5X60
THA-15	15"	381	300	r130	235	117,5	M110X2	133,25		22	1,5X60

TEKNİK ÖZELLİKLER / Technical Specifications

Sipariş Kodu Order Code	Ayna Ebadı Chucks Size	Ayna Stroku Jaw Stroke	Max. Devir Max.Speed	Max. Çekme Kuvveti Max. Drawbar Pull	Max. Sıkma Kuvveti Max. Gripping Force	Piston Stroku Shifter Stroke	Bağ. Flanş No Mounting Flange	Sert Ayak Min.-Max. Grippers Dia With Hard Jaws Min.-Max.	Ağırlığı (kg)
THA-06	6"	5,5	6000	21,5 KN	56 KN	13	A5	12-169	13,5
THA-08	8"	7,3	4900	34 KN	8 KN	17	A6	12-210	23
THA-10	10"	8,5	4200	43 KN	108 KN	20	A8	12-254	34
THA-12	12"	8,5	3000	55 KN	144 KN	20	A8	32-305	59
THA-15	15"	10,6	2500	71KN	179KN	23	A8-A11	45-381	120



2-4 AYAKLI AÇIK MERKEZ HİDROLİK AYVALAR

2 AND 4 JAWS HIGH SPEED OPEN-CENTER HYDRAULIC CHUCKS

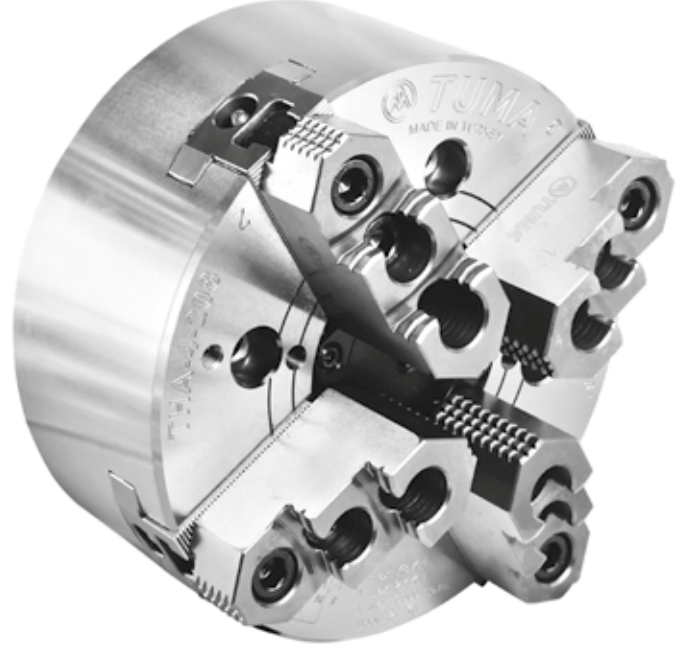
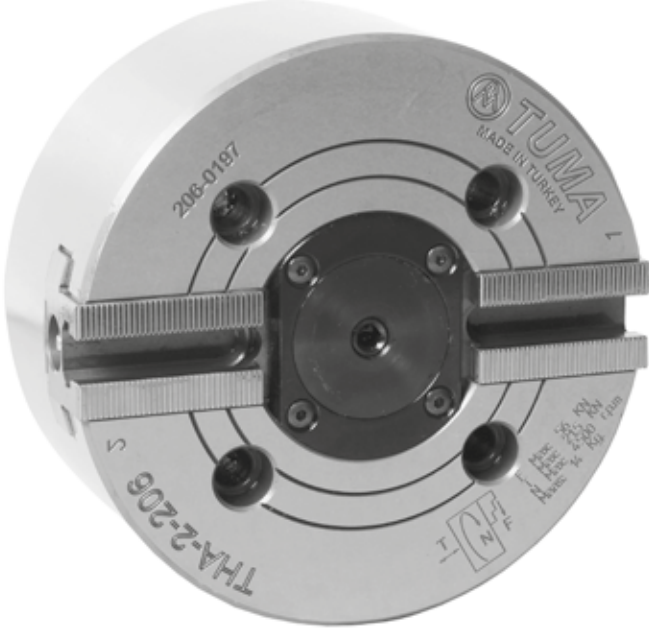

Devir Sayısı - Sıkma Kuvveti
Speed - Gripping Force Diagram

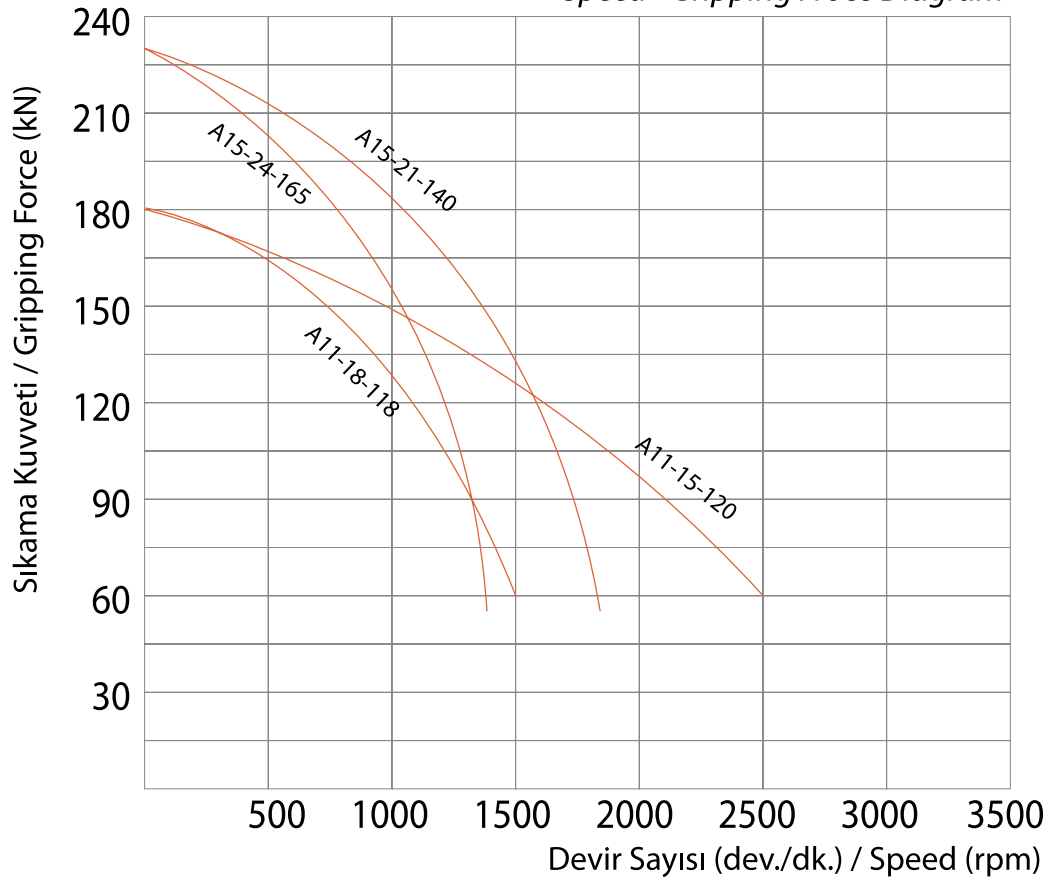

tuma.com.tr

2-4 AYAKLI AÇIK MERKEZ HİDROLİK AYINLAR

2 AND 4 JAWS HIGH SPEED OPEN-CENTER HYDRAULIC CHUCKS

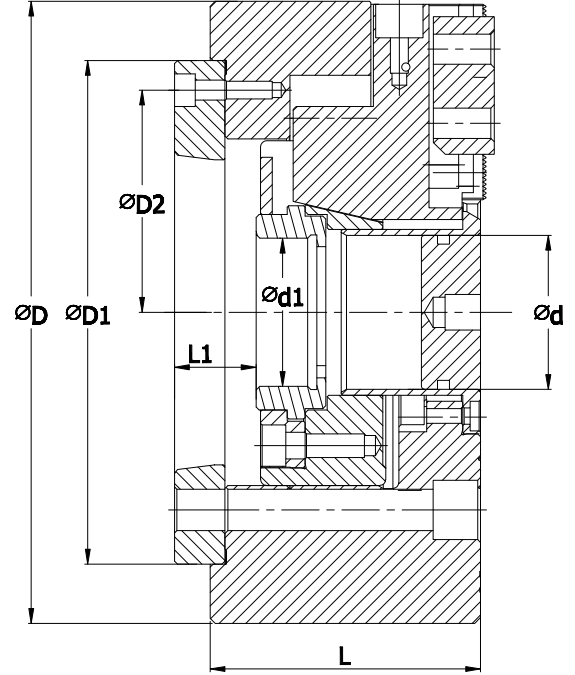
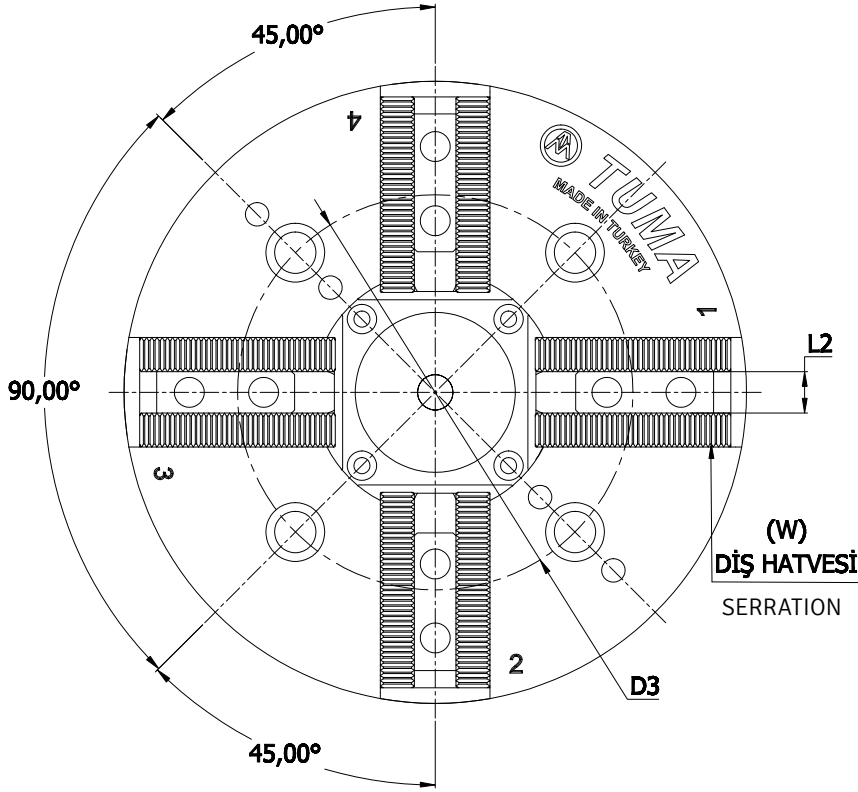

TR

THA geniş strok yüksek hız, 2 ve 4 ayaklı tipler.

- Taban ayak dişleri 1.5 x 60° ve 3mm x 60°
- Standart bağlama ISO-A
- Hareketli parçalar alaşımli çelikten imal edilmiş, sertleştirilmiş ve taşlanmış.
- 2 ve 4 ayaklı modelleri mevcuttur.
- Standart aksesuarları : Bağlantı civata ve somunları

EN

THA large stroke, high speed, 2 and 4 jaws versions.

- Serration 1.5 x 60° and 3mm x 60°
- Standard mounting ISO-A
- All parts are made of alloyed steel, hardened and grinded
- 2 and 4 jaws chucks are available
- Standard accessories : Mounting bolts and nuts

TEKNİK ÖLÇÜLER (mm) / Technical Dimensions

Sipariş Kodu Order Code	Ayna Ebadı Chucks Size	D	D1	D2	D3	d	d1	L	L1	L2	W
THA-06	6"	169	140	r58	104.80	45	M50X2	81	14	12	1,5X60
THA-08	8"	210	170	r75	133,4	52	M60X2	91.25	15,5	14	1,5X60
THA-10	10"	254	220	r95	171,4	75	M78X2	100,2	18	16	1,5X60
THA-12	12"	304	220	r95	171,4	91	M100X2	110	20,5	21	1,5X60
THA-15	15"	381	300	r130	235	117,5	M110X2	133,25	22		1,5X60

TEKNİK ÖZELLİKLER / Technical Specifications

Sipariş Kodu Order Code	Ayna Ebadı Chucks Size	Ayna Stroku Jaw Stroke	Max. Devir Max.Speed	Max. Çekme Kuvveti Max. Drawbar Pull	Max. Sıkma Kuvveti Max. Gripping Force	Piston Stroku Shifter Stroke	Bağ. Flanş No Mounting Flange	Sert Ayak Min.-Max. Sıkma Çapı Grippers Dia With Hard Jaws Min.-Max.	Ağırlığı (kg) Weight
THA-06	6"	5,5	6000	21,5 KN	56 KN	13	A5	12-169	13,5
THA-08	8"	7,3	4900	34 KN	8 KN	17	A6	12-210	23
THA-10	10"	8,5	4200	43 KN	108 KN	20	A8	12-254	34
THA-12	12"	8,5	3000	55 KN	144 KN	20	A8	32-305	59
THA-15	15"	10,6	2500	71 KN	179KN	23	A8-A11	45-381	120

TR

- Alışılmı çelikten mamüldür ve yüzey taşlaması yapılmıştır.



EN

- Produced from alloy steel and precision surface grinding is made

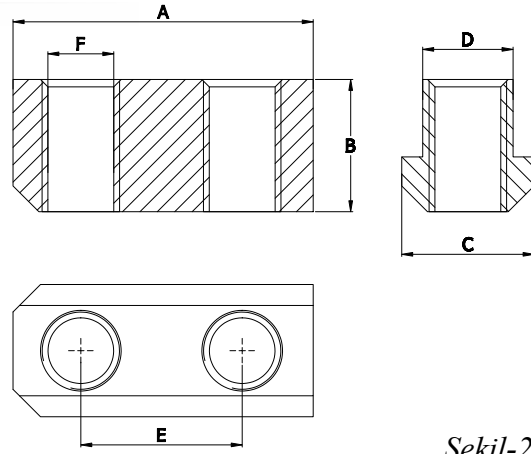
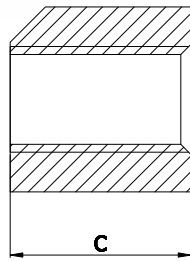
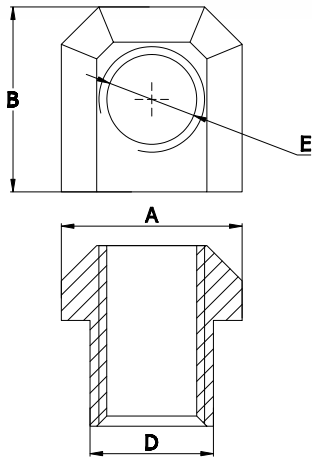

Şekil-1

Şekil-2



tuma.com.tr

Sipariş Kodu / Order Code	Ayna Çapı / Chuck Dia	Ölçüler / Dimensions						
		A	B	C	D	E	F	G
THA-TS-06-12-1-1	6"	17,50	15,00	18,50	12	11	M8	
THA-TS-08-14-1-1	8"	20,50	19,00	20,50	14	12	M12	
THA-TS-10-16-1-1	10"	23	20	23	16	14,50	M12	
THA-TS-12-18-1-1	12"	29	24	30	18	16	M14	
THA-TS-12-21-1-1	12"	29,50	24,00	27,50	21	16	M16	
THA-TS-15-22-1-3	15"	34	41,50	42	22	22	M20	
THA-TS-06-12-3-2	6"	36	18,50	17,50	12	20	M8	11
THA-TS-08-14-3-2	8"	46,50	20,50	20,50	14	25	M12	12
THA-TS-10-16-3-2	10"	50	23	23	16	30	M12	14,50
THA-TS-12-18-3-2	12"	54	30	29	18	30	M14	16
THA-TS-12-21-3-2	12"	55,50	27,50	29,50	21	30	M16	16
THA-TS-15-22-3-2	15"	73	41,50	34	22	43	M20	22

HİDROLİK AYNALAR İÇİN YUMUŞAK AYAK TORNALAMA APARATI

SOFT JAW MACHINING APPARATUS FOR HYDRAULIC CHUCKS

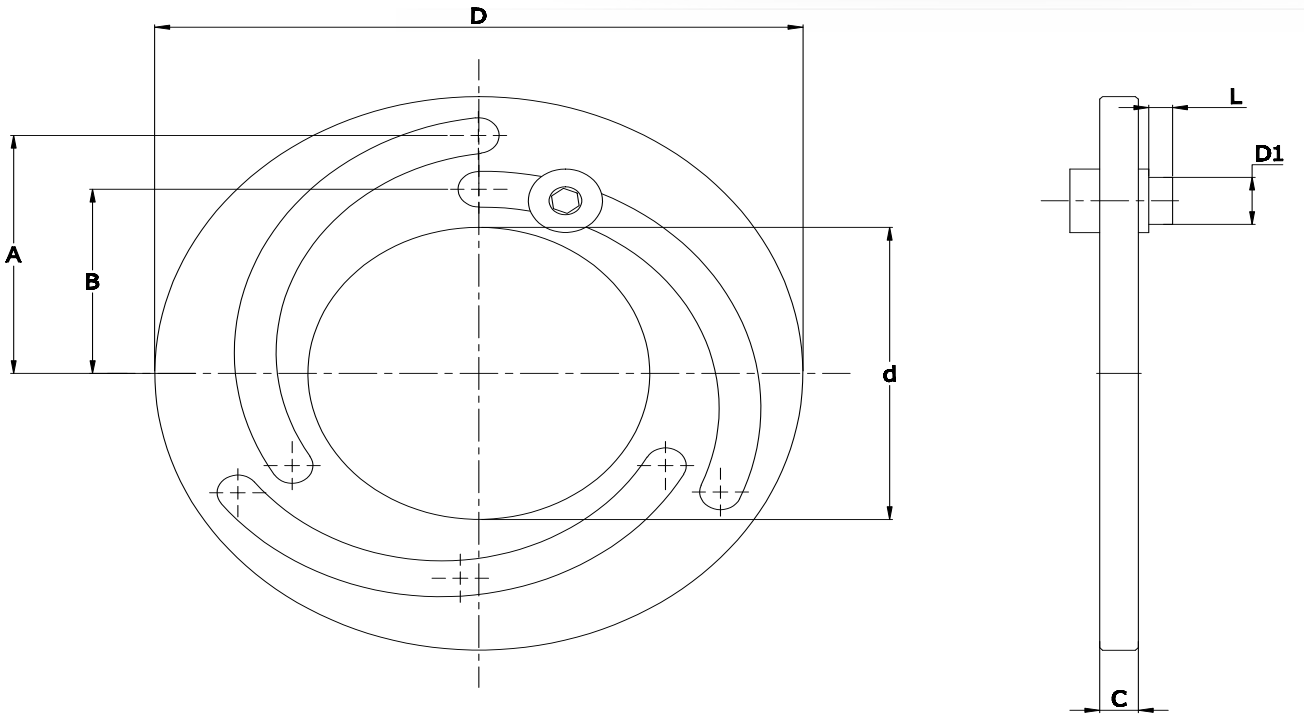

tuma.com.tr

Sipariş Kodu / Order Code	Ölçüler / Dimensions					
	D	D1	d	A	B	C
TTA-706	168	16,5	80	72	52	12
TTA-708	218	18,5	115	94	72	13
TTA-710	255	18,5	155	112,5	87,5	13
TTA-712	316	24,5	185	137	107	15
TTA-715	380	31,5	230	166	138	20



2 - 3 ve 4 AYAKLI HİDROLİK AYNA SERT AYAĞI

HARD JAWS FOR 2-3 AND 4 JAWS HYDRAULIC CHUCKS

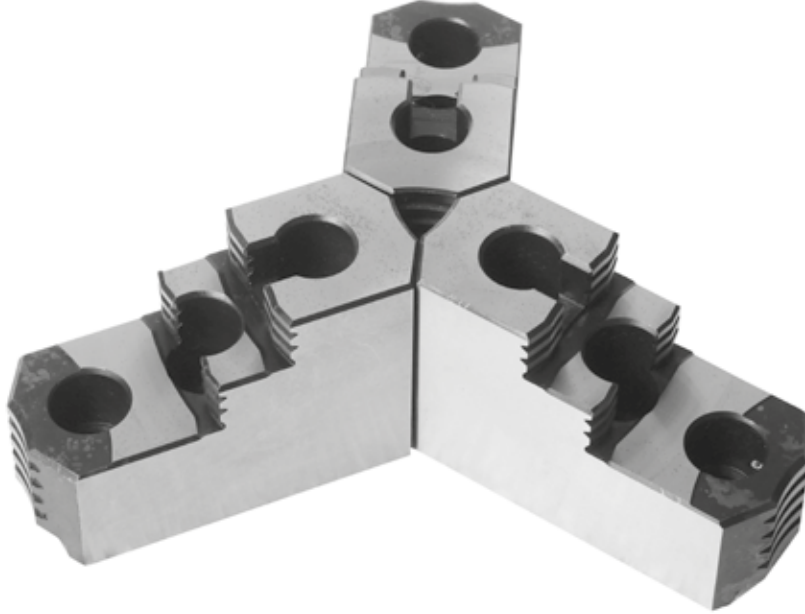

- Alaşımli çelikten mamuldür ve hassas yüzey taşlaması yapılmıştır. ^{TR}

- Produced from alloyed steel and surface grinding is made. ^{EN}

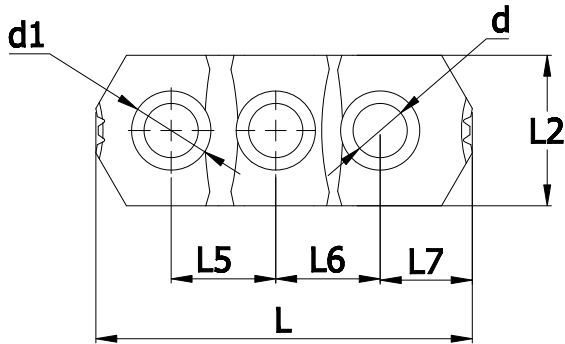
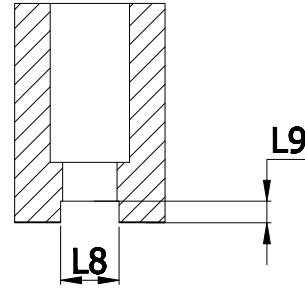
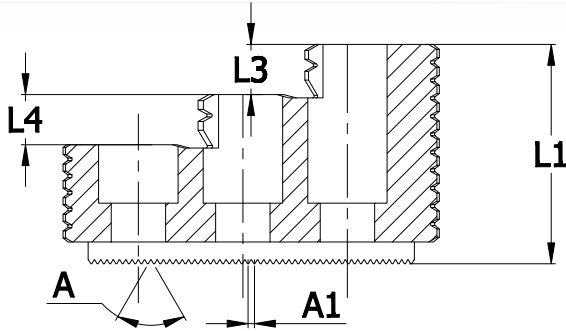

tuma.com.tr

Sipariş Kodu / Order Code	Ayna Çapı / Chuck No	DIŞ FORMU A-A1 SERRATION	Ölçüler / Dimensions										d	d1
			L	L1	L2	L3	L4	L5	L6	L7	L8	L9		
TSA-06-T1-2-12-1	6"	1.5X60°	72	39	32	9	9	20	20	18	12	5	17	11
TSA-08-T1-2-14-2	8"	1.5X60°	90	53	36	12	12	25	25	22	14	5	19	13
TSA-10-T1-2-16-2	10"	1.5X60°	102	60	42	13,50	13,50	30	30	24	16	5	19	13
TSA-12-T1-2-21-2	12"	1.5X60°	105	65	52	15	15	30	30	30	21	5	25	17
TSA-15-T1-2-22-2	15"	1.5X60°	151	86	62	20	20	43	43	26,5	22	8	32	21

HİDROLİK AYNA STANDART YUMUŞAK AYAKLARI

HYDRAULIC CHUCKS STANDARD SOFT JAWS

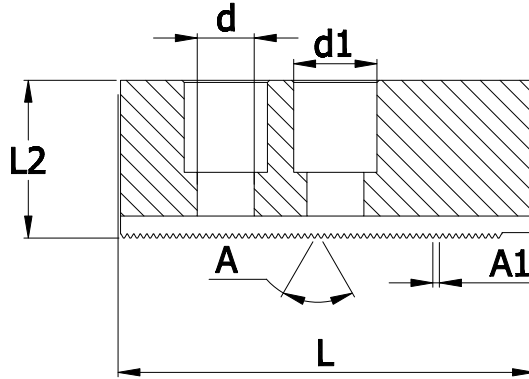
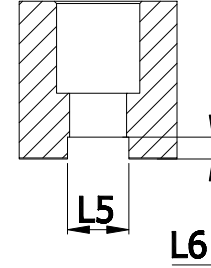
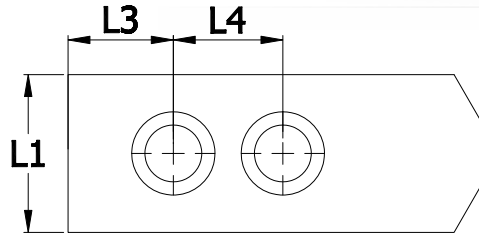
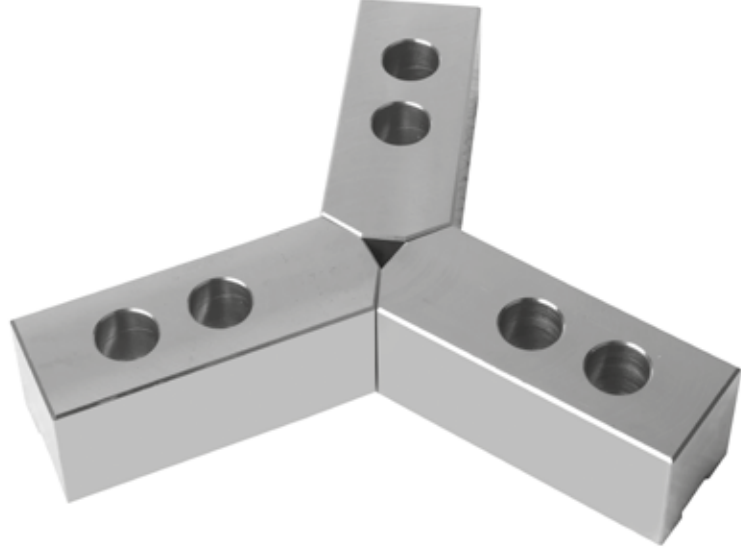

tuma.com.tr

Sipariş Kodu / Order Code	Ayna Çapı / Chuck Size	Dış FORMU (Serration) A-A1	Ölçüler / Dimensions								
			L	L1	L2	L3	L4	L5	L6	d	D1
TYA-06-T1-3-12-32	6"	1,5x60°	72	32	32	15	20	12	5	11	17
TYA-08-T1-3-14-3	8"	1,5x60°	95	36	36	24	25	14	5	13	19
TYA-10-T1-3-16-42	10"	1,5x60°	110	42	42	30	30	16	5	13	19
TYA-12-T1-3-18-52	12"	1,5x60°	130	52	52	39	30	18	5	15	23
TYA-12-T1-3-21-52	12"	1,5x60°	130	52	52	39	30	21	5	17	25
TYA-15-T1-3-22-62	15"	1,5x60°	165	62	62	37	43	22	8	21	32

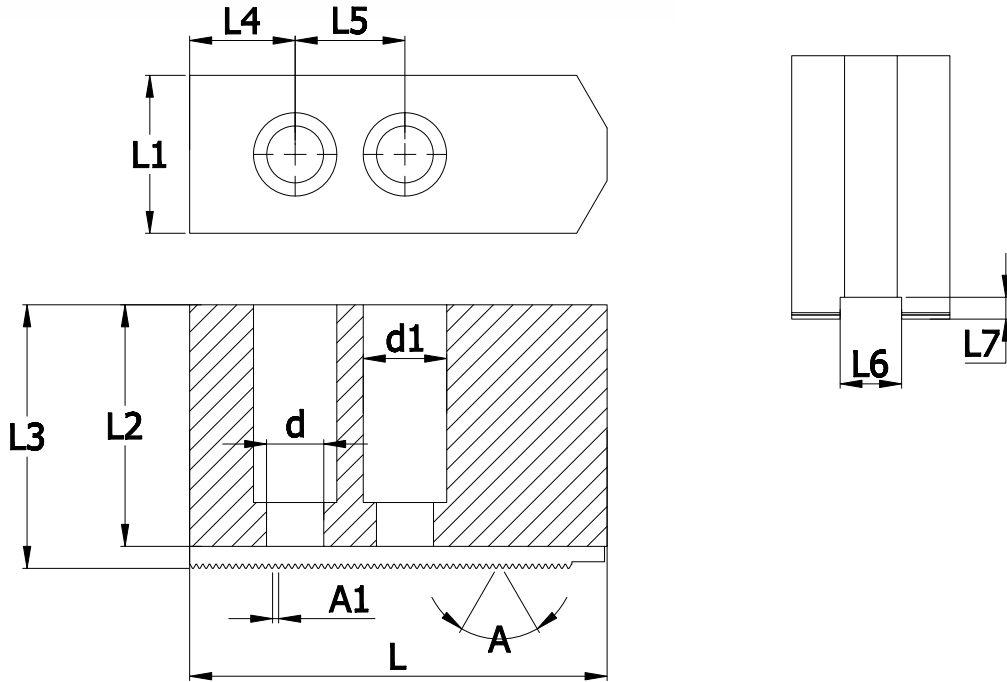

Sipariş Kodu / Order Code	Ayna Çapı / Chuck No	Diş FORMU (Serration)A-A1	Ölçüler / Dimensions									
			L	L1	L2	L3	L4	L5	L6	L7	d	D1
TYA-06-T1-3-12-55	6"	1,5X60°	72	32	50	55	15	20	12	5	11	17
TYA-08-T1-3-14-60	8"	1,5X60°	95	36	55	60	24	25	14	5	13	19
TYA-10-T1-3-16-80	10"	1,5X60°	110	42	75	80	30	30	16	5	13	19
TYA-12-T1-3-18-80	12"	1,5X60°	130	52	75	80	39	30	18	5	15	23
TYA-12-T1-3-21-80	12"	1,5X60°	130	52	75	80	39	30	21	5	17	25
TYA-12-T1-3-22-80	15"	1,5X60°	165	62	95	100	37	43	22	8	21	32

ÜNİVERSAL
AYNALAR



TUMA[®]
HASSAS TUTUCU TAKIMLAR



**UNIVERSAL
CHUCKS**



SÜPER HASSAS ÜNİVERSAL AYNALAR 3 AYAKLI SUPER PRECISION UNIVERSAL CHUCKS WITH 3 JAWS

TR

- Çelik gövde
- Sertleştirilmiş, balansı alınmış yüksek yüzey kalitesinde spiral.
- Sertleştirilmiş ve taşlanmış taban ayaklar
- Kademelendirilmiş, sertleştirilmiş ve taşlanmış döndürülebilir üst ayaklar.

EN

- Steel body
- Hardened and balanced scroll with high grade surface quality
- Hardened and grinded base jaws
- Stepped, hardened and grinded reversible top jaws

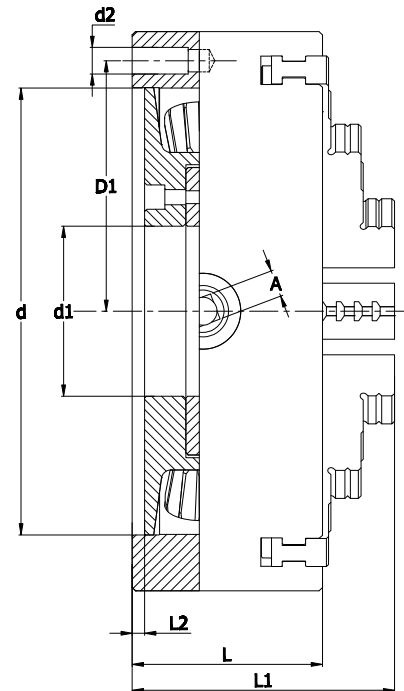
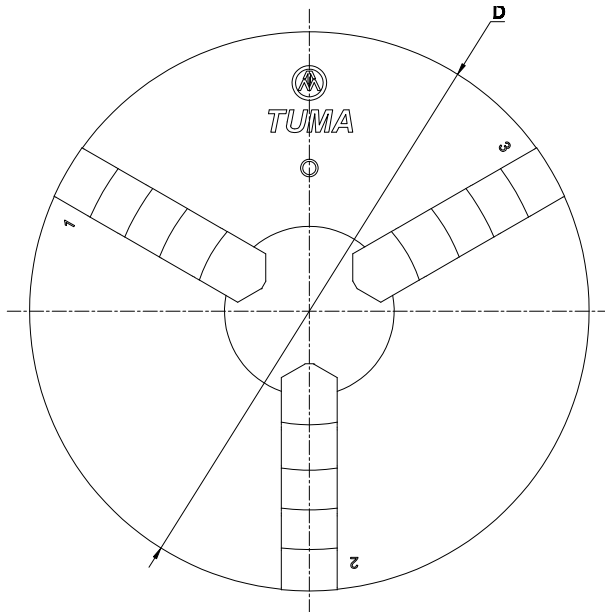

tuma.com.tr

TEKNİK ÖLÇÜLER(mm) / Technical Dimensions

Sipariş Kodu Order Code	D	D1	d	d1	d2	L1	L2	A	
USA-203	200	r88	160	57	3XM10	75	104,5	4	11
USA-253	250	r112	200	76	3XM12	85	117,25	5,5	12
USA-313	315	r143	260	103	3XM14	95	143,25	5,5	14
USA-403	400	r181	330	136	3XM16	108	157	5,5	17

SÜPER HASSAS ÜNİVERSAL AYNALAR 4 AYAKLI

SUPER PRECISION UNIVERSAL CHUCKS WITH 4 JAWS



- Çelik gövde
- Sertleştirilmiş, balansı alınmış yüksek yüzey kalitesinde spiral.
- Sertleştirilmiş ve taşlanmış taban ayaklar
- Kademelendirilmiş, sertleştirilmiş ve taşlanmış döndürülebilir üst ayaklar.

TR

- Steel body
- Hardened and balanced scroll with high grade surface quality
- Hardened and grinded base jaws
- Stepped, hardened and grinded reversible top jaws

EN

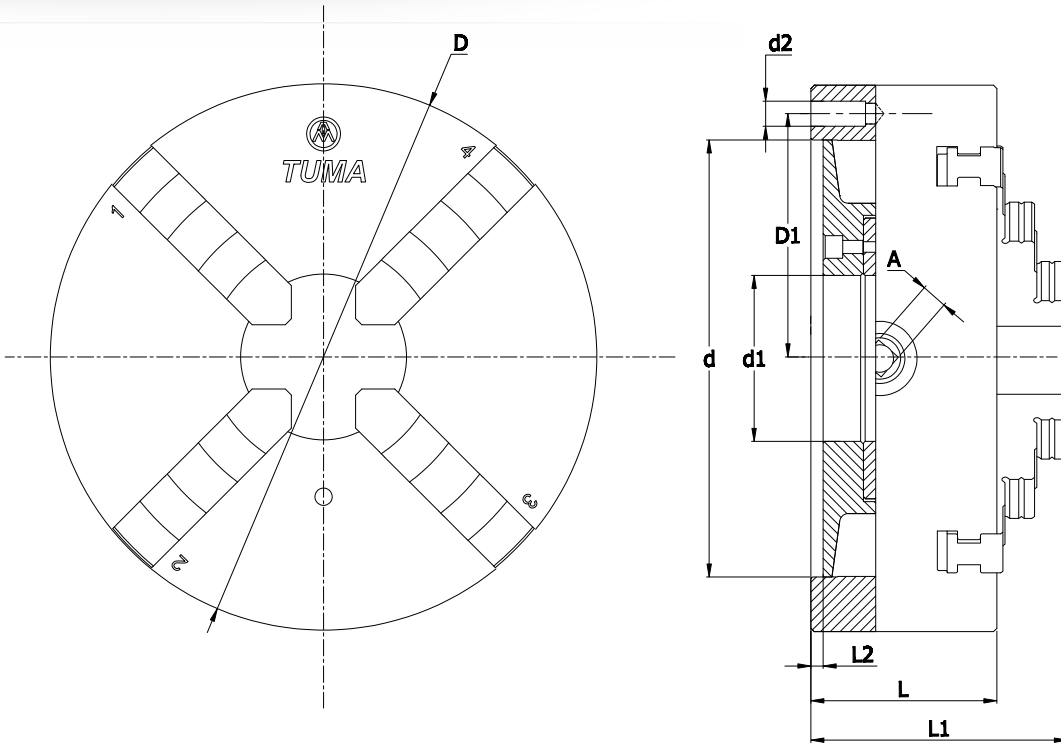

tuma.com.tr

TEKNİK ÖLÇÜLER(mm) / Technical Dimensions

Sipariş Kodu Order Code	D	D1	d	d1	d2	L	L1	L2	A
USA-204	200	r88	160	57	3XM10	75	104,5	4	11
USA-254	250	r112	200	76	3XM12	85	117,25	5,5	12
USA-314	315	r143	260	103	3XM14	95	143,25	5,5	14
USA-404	400	r181	330	136	3XM16	108	157	5,5	17



SÜPER HASSAS ÜNİVERSAL AYNALAR DÖNDÜRÜLEBİLİR 3 AYAKLI

TWO-PIECE REVERSIBLE JAWS 3-JAW SUPER PRECISION LATHE CHUCKS

TR

- Çelik gövde
- Sertleştirilmiş, balansı alınmış yüksek yüzey kalitesinde spiral.
- Sertleştirilmiş ve taşlanmış taban ayaklar
- Kademelendirilmiş, sertleştirilmiş ve taşlanmış döndürülebilir üst ayaklar.

EN

- Steel body
- Hardened and balanced scroll with high grade surface quality
- Hardened and grinded base jaws
- Stepped, hardened and grinded reversible top jaws

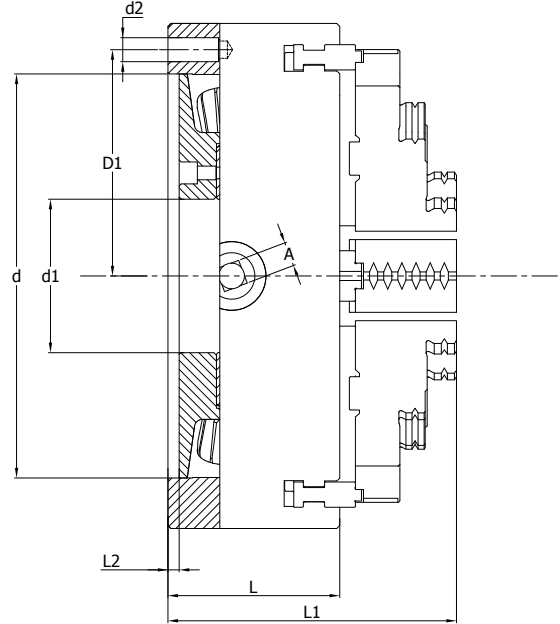
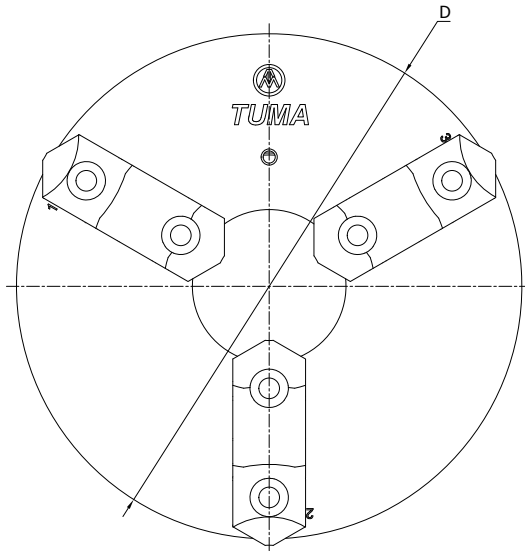
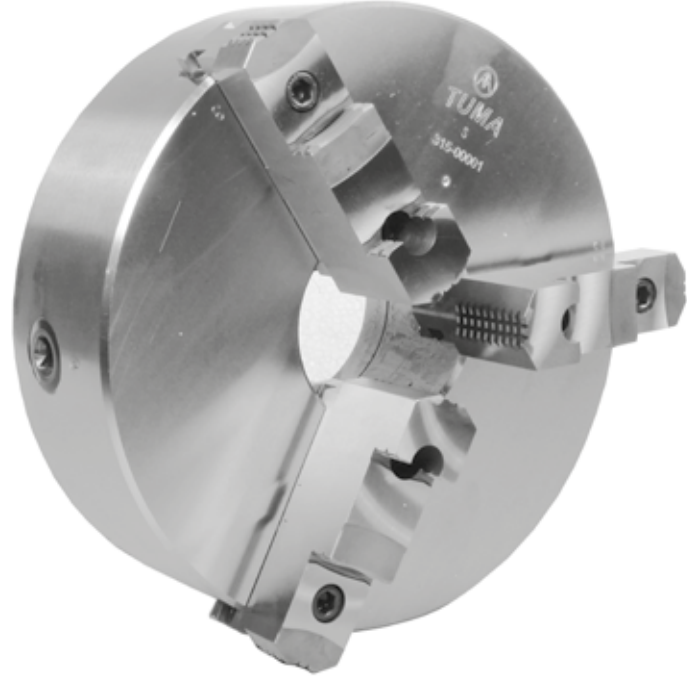

tuma.com.tr

TEKNİK ÖLÇÜLER(mm) / Technical Dimensions

Sipariş Kodu Order Code	D	D1	d	d1	d2	L	L1	L2	A
DSA-203	200	r88	160	57	3XM10	75	128,25	4	11
DSA-253	250	r112	200	76	3XM12	85	162,50	5,5	12
DSA-313	315	r143	260	103	3XM14	95	142,75	5,5	14
DSA-403	400	r181	330	136	3XM16	108	175,65	5,5	17

SÜPER HASSAS ÜNİVERSAL AYNALAR DÖNDÜRÜLEBİLİR 4 AYAKLI

TWO-PIECE REVERSIBLE JAWS 4-JAW SUPER PRECISION LATHE CHUCKS

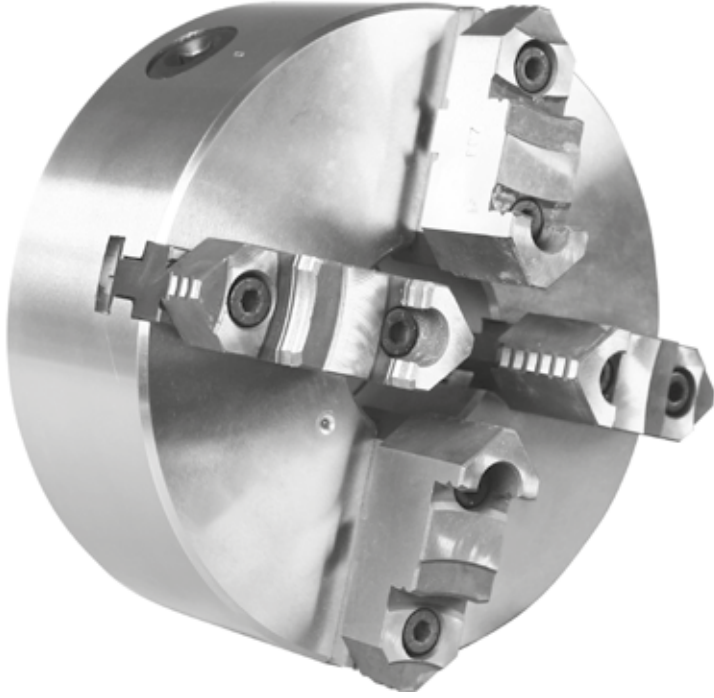

TR

- Çelik gövde
- Sertleştirilmiş, balansı alınmış yüksek yüzey kalitesinde spiral.
- Sertleştirilmiş ve taşlanmış taban ayaklar
- Kademelendirilmiş, sertleştirilmiş ve taşlanmış döndürülebilir üst ayaklar.

EN

- Steel body
- Hardened and balanced scroll with high grade surface quality
- Hardened and grinded base jaws
- Stepped, hardened and grinded reversible top jaws

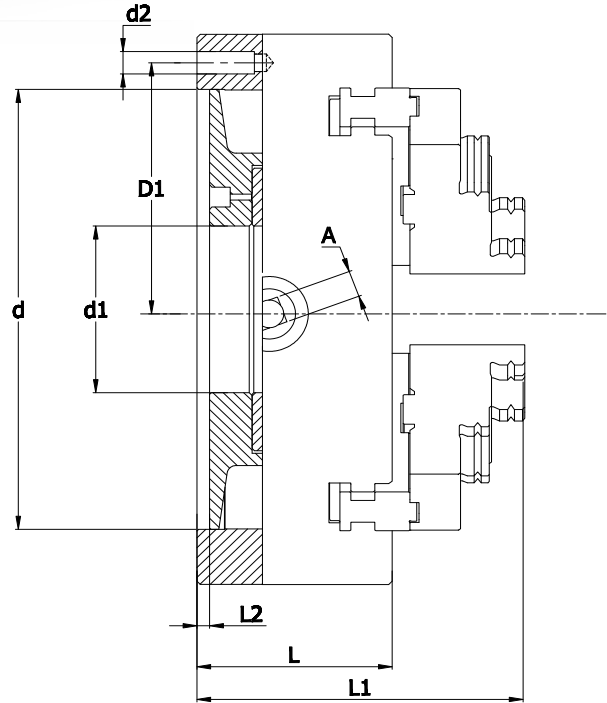
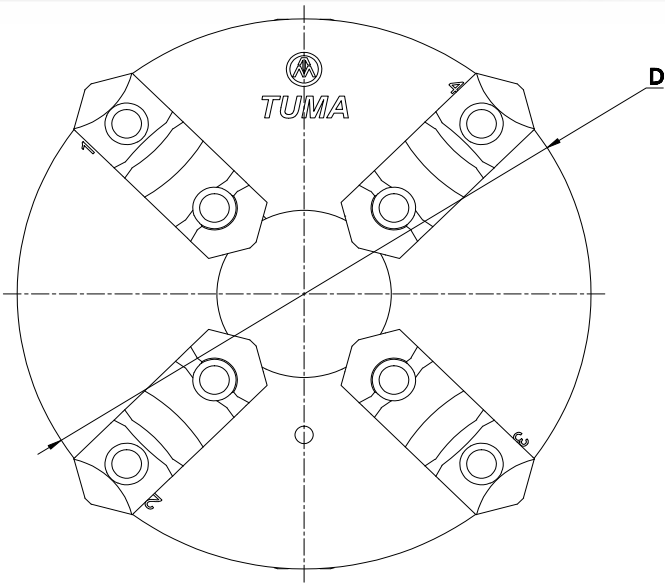

tuma.com.tr

TEKNİK ÖLÇÜLER(mm) / Technical Dimensions

Sipariş Kodu Order Code	D	D1	d	d1	d2	L	L1	L2	A
DSA-204	200	r88	160	57	3XM10	75	128,25	4	11
DSA-254	250	r112	200	76	3XM12	85	162,50	5,5	12
DSA-314	315	r143	260	103	3XM14	95	142,75	5,5	14
DSA-404	400	r181	330	136	3XM16	108	175,65	5,5	17



3-4 AYAKLI UNIVERSAL AYARLANABİLİR AYNA

UNIVERSAL LATHE CHUCKS WITH ADJUSTABLE 3-4-JAWS

TR

- Çelik gövde,
- Sertleştirilmiş balansı alınmış yüksek yüzey kapasitesinde spiral.
- Sertleştirilmiş ve taşlanmış taban ayaklar
- Kadelendirilmiş, sertleştirilmiş ve taşlanmış döndürülebilir üst ayaklar.

EN

- Steel body
- Hardened and balanced scroll with high grade surface quality
- Hardened and ground base jaws
- Stepped, hardened and ground reversible top jaws.

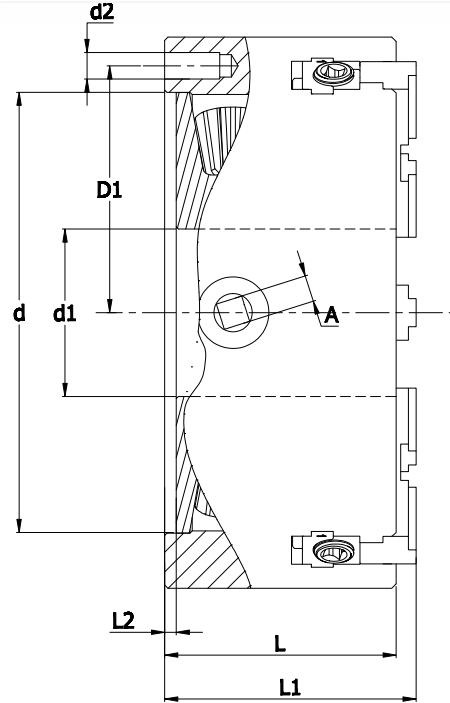
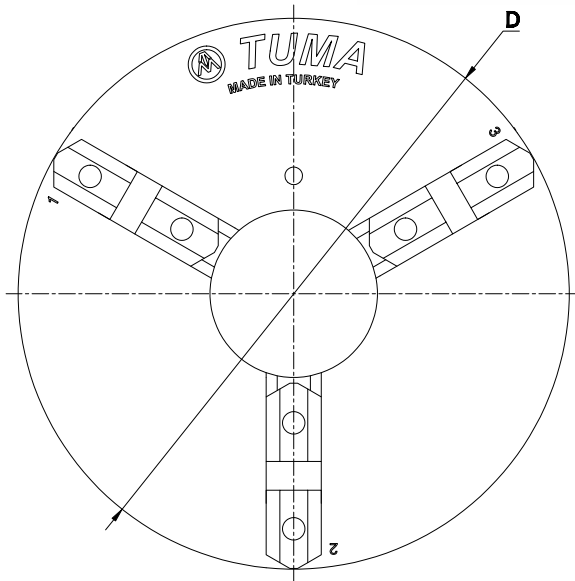

tuma.com.tr

TEKNİK ÖLÇÜLER(mm) / Technical Dimensions

Sipariş Kodu Order Code	D	D1	d	d1	d2	L	L1	L2	A
ASA-253	250	r112	200	76	3XM12	105	114	5,5	12
ASA-313	315	r143	260	103	3XM14	118	131,50	5,5	14
ASA-403	400	r181	330	136	3XM16	123	136	5,5	17

ÜNİVERSAL TORNA AYNASI BAĞLAMA FLANŞLARI

UNIVERSAL CHUCK FLANGES

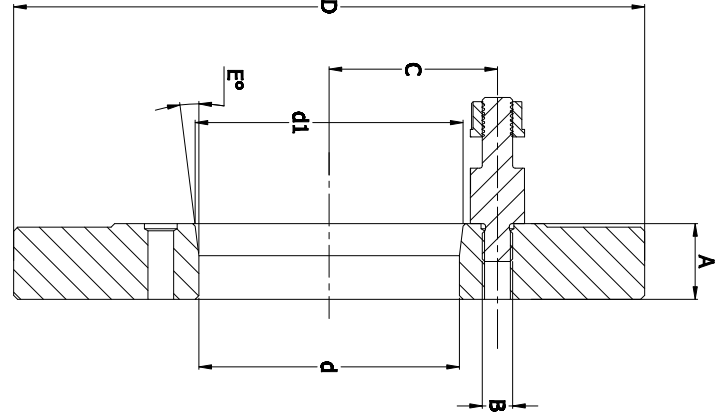

ÜNİVERSAL AYNA FLANSI (5 NR)

UNIVERSAL CHUCK FLANGES (5 NR)

Sipariş Kodu / Order Code	Tip / Type	Flanş No / Flange No	Saplama Ad/ Adjust- ment screw quantity	Ölçüler/Dimensions						
				D	d	d1	A	B	C	E°
TAF-160-05-27	Ø160	5 NR	4	160	79,60	82,44	25	M10	52,40	7,125°
TAF-200-05-27	Ø200	5 NR	4	200	79,60	82,44	25	M10	52,40	7,125°

ÜNİVERSAL AYNA FLANSI (6 NR)

UNIVERSAL CHUCK FLANGES (6 NR)

Sipariş Kodu / Order Code	Tip / Type	Flanş No / Flange No	Saplama Ad/ Adjust- ment screw quantity	Ölçüler/Dimensions						
				D	d	d1	A	B	C	E°
TAF-160-06-27	Ø160	6 NR	4	160	103,20	106,13	25	M12	66,70	7,125°
TAF-200-06-27	Ø200	6 NR	4	200	103,20	106,13	25	M12	66,70	7,125°
TAF-250-06-27	Ø250	6 NR	4	250	103,20	106,13	30	M12	66,70	7,125°
TAF-315-06-27	Ø315	6 NR	4	315	103,20	106,13	35	M12	66,70	7,125°
TAF-400-06-27	Ø400	6 NR	4	400	103,20	106,13	36	M12	66,70	7,125°

ÜNİVERSAL AYNA FLANSI (8 NR)

UNIVERSAL CHUCK FLANGES (8 NR)

Sipariş Kodu / Order Code	Tip / Type	Flanş No / Flange No	Saplama Ad/ Adjust- ment screw quantity	Ölçüler/Dimensions						
				D	d	d1	A	B	C	E°
TAF-200-08-27	Ø200	8 NR	4	200	136,20	139,719	25	M16	85,70	7,125°
TAF-250-08-27	Ø250	8 NR	4	250	136,20	139,719	30	M16	85,70	7,125°
TAF-315-08-27	Ø315	8 NR	4	315	136,20	139,719	35	M16	85,70	7,125°
TAF-400-08-27	Ø400	8 NR	4	400	136,20	139,719	36	M16	85,70	7,125°
TAF-500-08-27	Ø500	8 NR	4	500	136,20	139,719	40	M16	85,70	7,125°

ÜNİVERSAL AYNA FLANSI (11 NR)

UNIVERSAL CHUCK FLANGES (11 NR)

Sipariş Kodu / Order Code	Tip / Type	Flanş No / Flange No	Saplama Ad/ Adjust- ment screw quantity	Ölçüler/Dimensions						
				D	d	d1	A	B	C	E°
TAF-315-11-27	Ø315	11 NR	6	315	192,90	196,620	35	M20	117,50	7,125°
TAF-400-11-27	Ø400	11 NR	6	400	192,90	196,620	36	M20	117,50	7,125°
TAF-500-11-27	Ø500	11 NR	6	500	192,90	196,620	40	M20	117,50	7,125°



ÜNİVERSAL AYNALAR YEDEK PARÇALAR

SPARE PARTS OF UNIVERSAL CHUCKS

ÜNİVERSAL AYNA YEDEK PARÇALAR SPARE PARTS OF UNIVERSAL CHUCKS

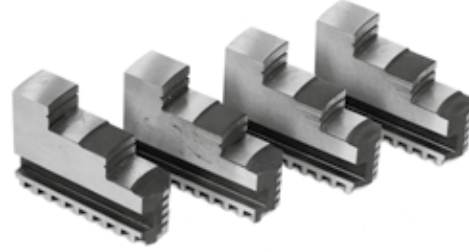

3 LÜ TERS DÜZ AYAK TAKIM INTERNAL EXTERNAL JAW SET WITH 3 PCS JAWS

ÇAPI Diameters	SİPARİŞ KODU Order Code
200	203DA
250	253DA
315	313DA
400	403DA

4 LÜ TERS DÜZ AYAK TAKIM INTERNAL EXTERNAL JAW SET WITH 4 PCS JAWS

SİPARİŞ KODU Order Code
204DA
254DA
314DA
404DA



PİNYON PINION

ÇAPI Diameters	SİPARİŞ KODU Order Code
200	20PN
250	25PN
315	31PN
400	40PN



ANAHTAR KEY

SİPARİŞ KODU Order Code
20AN
25AN
31AN
40AN

AYARLANABİLİR AYNA YEDEK PARÇALARI SPARE PARTS OF ADJUSTABLE CHUCKS



3 LÜ TAKIM TABAN AYAK BASE JAWS SET AS 3 PCS JAWS

ÇAPI Diameters	SİPARİŞ KODU Order Code
250	253ATA
315	313ATA
400	403ATA

4 LÜ TAKIM TABAN AYAK BASE JAWS SET AS 4 PCS JAWS

SİPARİŞ KODU Order Code
254ATA
314ATA
404ATA

3 LÜ TAKIM ÜST AYAK TOP JAWS SET AS 3 PCS JAWS

SİPARİŞ KODU Order Code
253AUA
313AUA
403AUA

4 LÜ TAKIM ÜST AYAK TOP JAWS SET AS 4 PCS JAWS

SİPARİŞ KODU Order Code
254AUA
314AUA
404AUA

ÜNİVERSAL AYNALAR YEDEK PARÇALAR

SPARE PARTS OF UNIVERSAL CHUCKS



AYAR VİDASI
ADJUSTING SCREW

ÇAPI Diameters	SİPARİŞ KODU Order Code
250	25AV
315	31AV
400	40AV



SPİRAL
SPIRAL

ÇAPI Diameters	SİPARİŞ KODU Order Code
200	203 TS
250	253 TS
315	313 TS
400	403 TS

DÖNDÜRÜLEBİLİR AYNA YEDEK PARÇALAR / REVERSIBLE SPARE PARTS OF CHUCKS



3 LÜ TAKIM TABAN AYAK
BASE JAWS SET AS 3 PCS JAWS

ÇAPI Diameters	SİPARİŞ KODU Order Code
200	203DTA
250	253DTA
315	313DTA
400	403DTA

4 LÜ TAKIM TABAN AYAK
BASE JAWS SET AS 4 PCS JAWS

SİPARİŞ KODU Order Code
204DTA
254DTA
314DTA
404DTA

3 LÜ TAKIM ÜST AYAK
TOP JAWS SET AS 3 PCS JAWS

SİPARİŞ KODU Order Code
203DUA
253DUA
313DUA
403DUA

4 LÜ TAKIM ÜST AYAK
TOP JAWS SET AS 4 PCS JAWS

SİPARİŞ KODU Order Code
204DUA
254DUA
314DUA
404DUA



3 LÜ TAKIM YUMUŞAK AYAK
SOFT JAWS SET AS 3 PCS JAWS

ÇAPI Diameters	SİPARİŞ KODU Order Code
200	203DYA
250	253DYA
315	313DYA
400	403DYA

4 LÜ TAKIM YUMUŞAK AYAK
SOFT JAWS SET AS 4 PCS JAWS

SİPARİŞ KODU Order Code
204DYA
254DYA
314DYA
404DYA

HASSAS
DÖNER
PUNTALAR



TUMA[®]
HASSAS TUTUCU TAKIMLAR



**PRECISION
ROTARY
CENTERS**

HASSAS DÖNER PUNTALAR

PRECISION ROTARY CENTERS



S-500

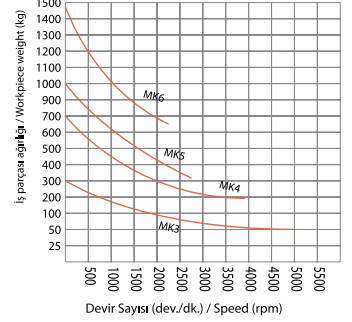
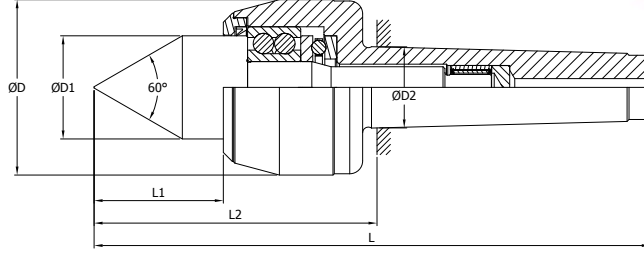

S-510

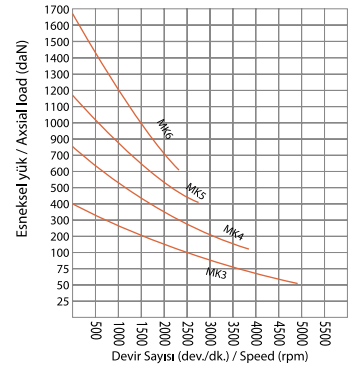
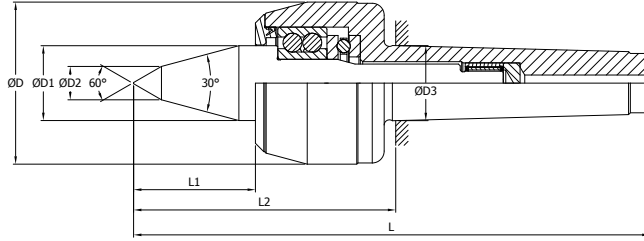

S-520

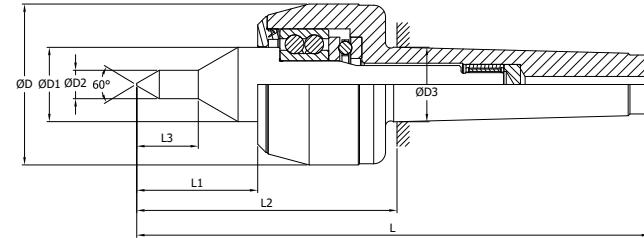

S-500

Sipariş Kodu / Order Code	Mors Koniği / Mors Taper	Ölçüler / Dimensions						Uç Salgısı / Center Runout
		D	D1	D2	L	L1	L2	
S-502	2	45	19	17,780	130,50	24	66,500	0,005
S-503	3	58	25	23,830	164,500	30	83,500	0,005
S-504	4	68	40	31,267	215,60	50,10	113,10	0,005
S-505	5	88	44,45	44,399	260,55	51,55	131,05	0,005
S-506	6	105	44,45	63,348	333,85	59	152	0,010

S-510

Sipariş Kodu / Order Code	Mors Koniği / Mors Taper	Ölçüler / Dimensions							Uç Salgısı / Center Runout
		D	D1	D2	D3	L	L1	L2	
S-512	2	45	19	10	17,780	136,50	30	72,50	0,005
S-513	3	58	25	12	23,830	175,50	41	94,50	0,005
S-514	4	68	31,40	14	31,267	216,60	51,10	114,10	0,005
S-515	5	88	37,75	16	44,399	269,55	60,55	140,05	0,005
S-516	6	105	44,45	18	63,348	349,85	75	168	0,010

S-520

Sipariş Kodu / Order Code	Mors Koniği / Mors Taper	Ölçüler / Dimensions								Uç Salgısı / Center Runout
		D	D1	D2	D3	L	L1	L2	L3	
S-522	2	45	19	10	17,780	136,50	30	72,50	16	0,005
S-523	3	58	25	12	23,830	175,50	41	94,50	20	0,005
S-524	4	68	31,40	14	31,267	216,60	51,10	114,10	26	0,005
S-525	5	88	37,75	16	44,399	269,55	60,55	140,05	30	0,005
S-526	6	105	44,45	18	63,348	349,85	75	168	40	0,01

TR

- Çelik gövde, yüksek yük kapasitesi, yüksek hız.

- Yüksek hassasiyetli rulmanlar
- Yüksek salgı hassasiyeti

EN

- Steel body, high load capacity, high speed
- High precision roller bearings
- High concentricity precision



tuma.com.tr



DEĞİŞEBİLİR BORU PUNTALARI

CHANGEABLE PIPE CENTERS

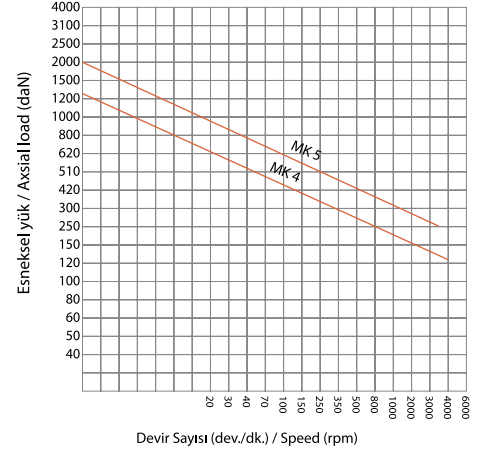
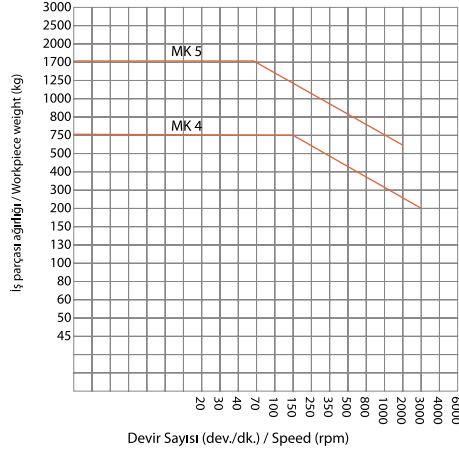

TR

- Çelik gövde, yüksek yük kapasitesi, yüksek hız.

- Yüksek hassasiyetli rulmanlar
- Yüksek salgı hassasiyeti

EN

- Steel body, high load capacity, high speed

- High precision roller bearings
- High concentricity precision

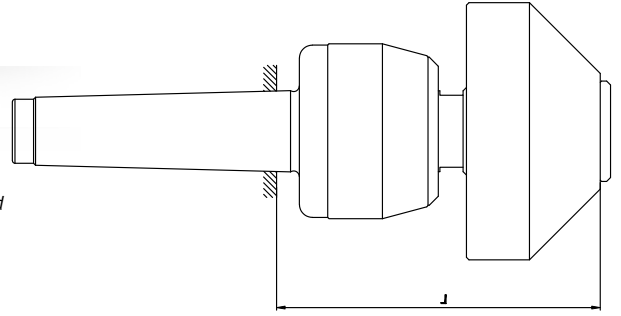

Sipariş Kodu / Order Code	Tip / Type	Mors Koniği / Mors Taper	Ölçüler / Dimensions				
			L	D	D1	d	A
SPS-504-100-60	MK4	4	52	100	45	34	60
SPS-504-100-75	MK4	4	52	100	45	34	75
SPS-504-100-90	MK4	4	52	100	45	34	90
SPS-504-150-60	MK4	4	52	150	95	34	60
SPS-504-150-75	MK4	4	52	150	95	34	75
SPS-504-150-90	MK4	4	52	150	95	34	90
SPS-504-200-60	MK4	4	52	200	145	34	60
SPS-504-200-75	MK4	4	52	200	145	34	75
SPS-504-200-90	MK4	4	52	200	145	34	90
SPS-505-100-60	MK5	5	52	100	45	40	60
SPS-505-100-75	MK5	5	52	100	45	40	75
SPS-505-100-90	MK5	5	52	100	45	40	90
SPS-505-150-60	MK5	5	52	150	95	40	60
SPS-505-150-75	MK5	5	52	150	95	40	75
SPS-505-150-90	MK5	5	52	150	95	40	90
SPS-505-200-60	MK5	5	52	200	145	40	60
SPS-505-200-75	MK5	5	52	200	145	40	75
SPS-505-200-90	MK5	5	52	200	145	40	90

YÜKSEK DEVİRLİ SÜPER HASSAS PUNTALAR

HIGH SPEED SUPER PRECISION CENTERS



C-510

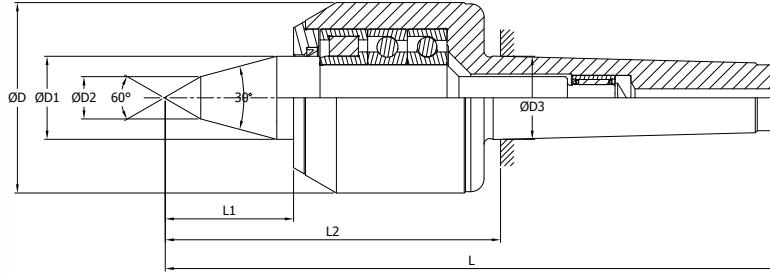

C-520

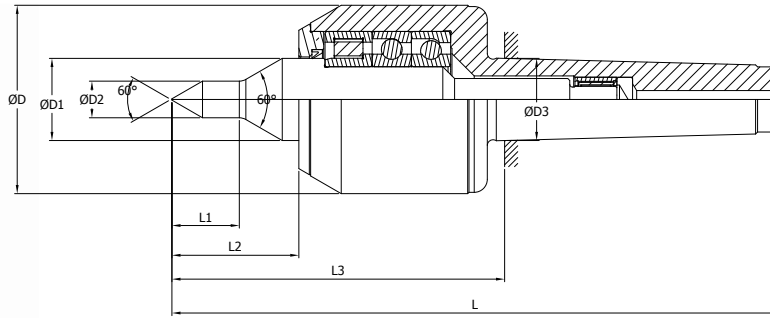

C-530

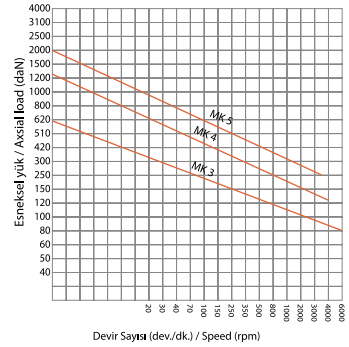
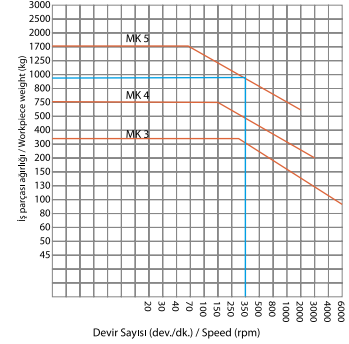
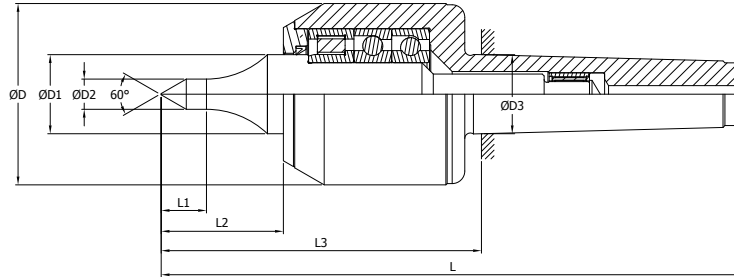

C-510

Sipariş Kodu / Order Code	Tip / Type	Mors Koniği / Mors Taper	Ölçüler / Dimensions						Uç Salgısı / Center Runout	Ağırlık / Weight
			D	D1	D2	L	L1	L2		
C-513	C 510	3	58	25	12	23,83	189	41	107,90	0,005
C-514	C 510	4	72	31,40	16	31,267	232	48,50	129,50	0,005
C-515	C 510	5	72	31,40	16	44,399	269,50	53	140	0,005

C-520

Sipariş Kodu / Order Code	Tip / Type	Mors Koniği / Mors Taper	Ölçüler / Dimensions							Uç Salgısı / Center Runout	
			D	D1	D2	D3	L	L1	L2		L3
C-523	C 520	3	58	25	10	23,825	189	20	41	107,90	0,005
C-524	C 520	4	72	31,40	14	31,267	232	25,75	48,50	129,50	0,005
C-525	C 520	5	72	31,40	16	44,397	269,50	27,48	53	140	0,005

C-530

Sipariş Kodu / Order Code	Tip / Type	Mors Koniği / Mors Taper	Ölçüler / Dimensions								Uç Salgısı / Center Runout
			D	D1	D2	D3	L	L1	L2	L3	
C-533	C 530	3	58	25	10	23,825	189	15,15	41	107,90	0,005
C-534	C 530	4	72	31,40	12	31,267	232	17,98	48,50	129,50	0,005
C-535	C 530	5	72	31,40	14	44,399	269,50	27	53	140	0,005

TR

- Çelik gövde, yüksek yük kapasitesi, yüksek hız.

- Yüksek hassasiyetli rulmanlar.
- Maksimum yüksek devir.

EN

- Steel body, high load capacity, high speed.

- High precision roller bearings.
- Maximum speed



tuma.com.tr



CK-500

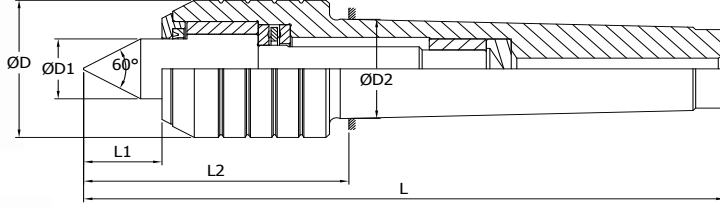

CK-510

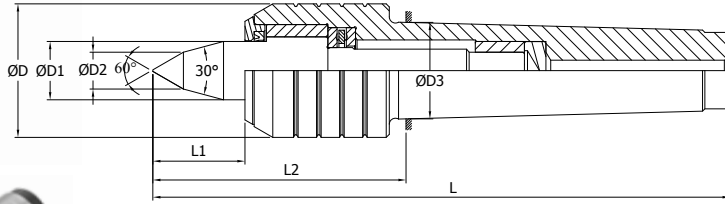

CK-520

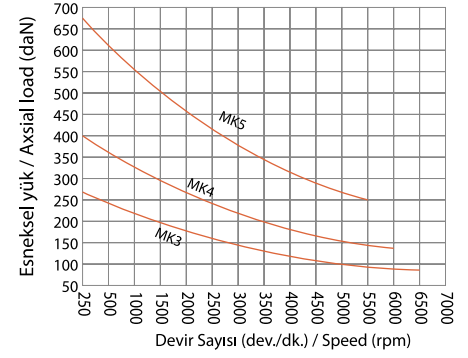
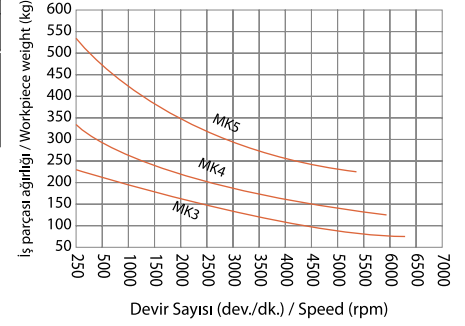
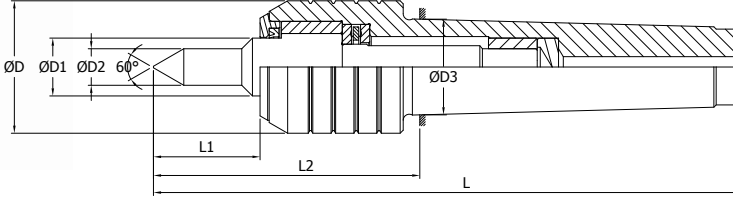

CK-500

Sipariş Kodu / Order Code	Tip / Type	Mors Koniği / Mors Taper	Ölçüler / Dimensions						Uç Salgısı / Center Runout
			D	D1	D2	L	L1	L2	
CK-502	CK 500	2	32	15	17,780	126	18	62	0,005
CK-503	CK500	3	40	20	23,825	157,50	25	76,50	0,005
CK-504	CK500	4	43,50	19	31,267	180	22	77,50	0,005
CK-505	CK500	5	68	31,75	44,399	246	41,20	116,50	0,005

CK-510

Sipariş Kodu / Order Code	Tip / Type	Mors Koniği / Mors Taper	Ölçüler / Dimensions							Uç Salgısı / Center Runout
			D	D1	D2	D3	L	L1	L2	
CK-512	CK510	2	32	15	10	17,78	136,50	28,50	72,50	0,005
CK-513	CK510	3	40	20	12	23,825	164,50	32	83,50	0,005
CK-514	CK510	4	43,50	19	12	31,267	188	48,50	85,50	0,005
CK-515	CK510	5	68	32	14	44,399	257	52,20	127	0,005

CK-520

Sipariş Kodu / Order Code	Tip / Type	Mors Koniği / Mors Taper	Ölçüler / Dimensions							Uç Salgısı / Center Runout
			D	D1	D2	D3	L	L1	L2	
CK-522	CK520	2	32	15	6	17,78	136,50	28,50	72,50	0,005
CK-523	CK520	3	40	20	12	23,825	164,50	32	83,50	0,005
CK-524	CK520	4	43,50	19	12	31,267	188,00	48,50	90,50	0,005
CK-525	CK520	5	68	32	14	44,399	265,00	60,20	135,50	0,005

TR

- Çelik gövde, yüksek hız.
- Yüksek hassasiyetli rulmanlar
- Yüksek salgı hassasiyeti
- Yeni dizayn, daha küçük gövde

EN

- Steel body, high load capacity, high speed
- High precision roller bearings
- High concentricity precision
- New design with small casing diameter



AĞIR YÜKLER İÇİN HASSAS DÖNER PUNTALAR

PRECISION ROTARY CENTERS FOR HEAVY LOADS



A-500

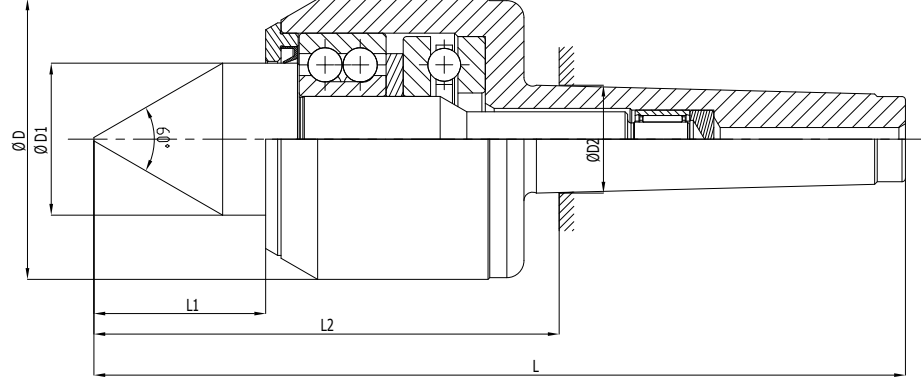

A-510

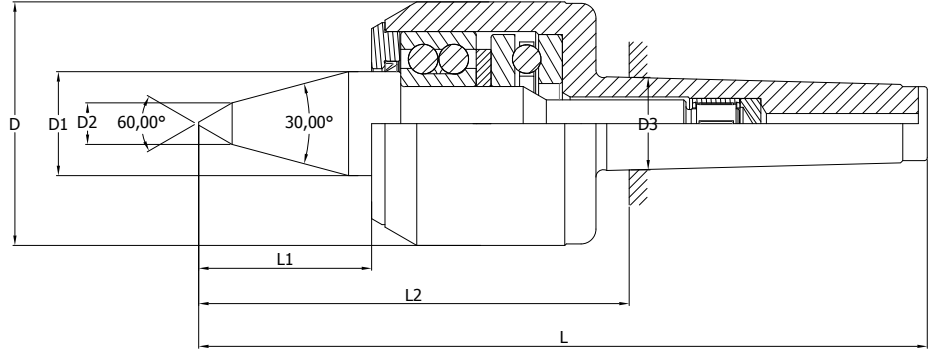

TR

- Çelik gövde, yüksek yük kapasitesi, yüksek hız.
- Yüksek hassasiyetli rulmanlar.
- Yüksek salgı hassasiyeti

EN

- Steel body, high load capacity, high speed.
- High precision roller bearings.
- High concentricity precision

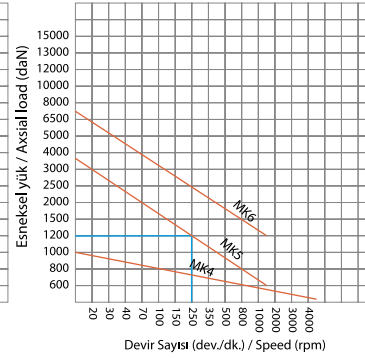
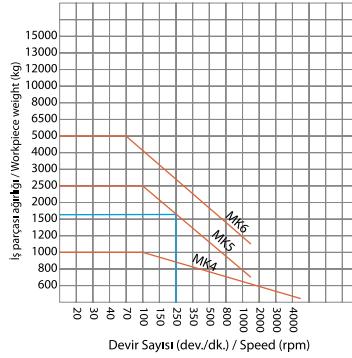

tuma.com.tr

A-500

Sipariş Kodu / Order Code	Tip / Type	Mors Koniği / Mors Taper	Ölçüler / Dimensions						Uç Salgısı / Center Runout
			D	D1	D2	L	L1	L2	
A-504	A-500	4	82	44,45	31,267	237,20	50,20	134,70	0,005
A-505	A-500	5	95	50	44,399	281,20	57,70	151,70	0,005
A-506	A-500	6	115	70	63,348	365,90	76,90	184,05	0,01

A-510

Sipariş Kodu / Order Code	Tip / Type	Mors Koniği / Mors Taper	Ölçüler / Dimensions						Uç Salgısı / Center Runout	Ağırlık / Weight
			D	D1	D2	L	L1	L2		
A-514	A-510	4	82	35	14	31,267	245,20	58,20	142,70	0,005
A-515	A-510	5	95	40	20	44,399	288,70	65,20	159,20	0,005
A-516	A-510	6	115	50	18	63,348	366,90	77,90	185,05	0,01



75° BORU PUNTALARI (S-610)

75° PIPE CENTERS (S-610)

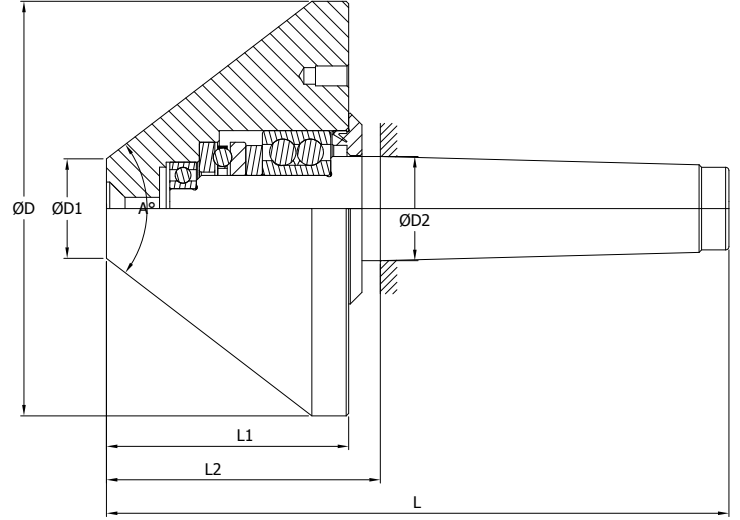

TR

- Çelik gövde
- Yüksek hassasiyet
- Yüksek salgı hassasiyeti

EN

- Steel body
- High precision
- High concentricity precision



tuma.com.tr

Sipariş Kodu / Order Code	Tip / Type	Mors Koniği / Mors Taper	Ölçüler / Dimensions							Uç Salgısı / Center Runout
			D	D1	D2	L	L1	L2	A°	
S613-80	MK3	3	80	25	23,825	156	64	75	75°	0,005
S613-100	MK3	3	100	25	23,825	169,060	77	88,10	75°	0,005
S613-125	MK3	3	125	30	23,825	165,10	73	84,10	75°	0,005
S614-80	MK4	4	80	25	31,267	177,40	64	74,90	75°	0,005
S614-100	MK4	4	100	25	31,267	191,60	77	89,10	75°	0,005
S614-125	MK4	4	125	30	31,267	187,60	73	85,10	75°	0,005
S614-150	MK4	4	150	50	31,267	208,05	90	105,55	75°	0,005
S614-175	MK4	4	175	50	31,267	211,05	93	10,55	75°	0,005
S615-100	MK5	5	100	25	44,399	221,10	77	91,60	75°	0,005
S615-125	MK5	5	125	30	44,399	217,10	73	87,60	75°	0,005
S615-150	MK5	5	150	50	44,399	235,05	90	105,55	75°	0,005
S615-175	MK5	5	175	50	44,399	238,05	93	108,55	75°	0,005
S616-175	MK6	6	175	50	63,348	293,00	93	111,00	75°	0,010

60° BORU PUNTALARI (S-600)

60° PIPE CENTERS (S-600)

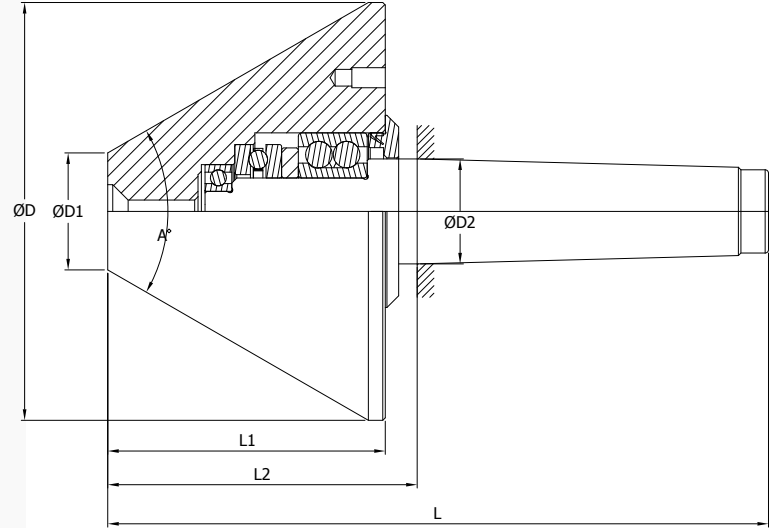

tuma.com.tr

TR

- Çelik gövde
- Yüksek hassasiyet
- Yüksek salgı hassasiyeti

EN

- Steel body
- High precision
- High concentricity precision

Sipariş Kodu / Order Code	Tip / Type	Mors Koniği / Mors Taper	Ölçüler / Dimensions							Uç Salgısı / Center Runout
			D	D1	D2	L	L1	L2	A°	
S603-80	MK3	3	80	25	23,825	156	64	75	60°	0,005
S603-100	MK3	3	100	25	23,285	169,10	77	88,10	60°	0,005
S603-125	MK3	3	125	35	23,825	175,10	83	94,10	60°	0,005
S604-80	MK4	4	80	25	31,267	177,40	64	74,90	60°	0,005
S604-100	MK4	4	100	25	31,267	191,60	77	89,10	60°	0,005
S604-125	MK4	4	125	35	31,267	197,60	83	89,10	60°	0,005
S604-150	MK4	4	150	50	31,267	213,05	95	110,55	60°	0,005
S604-175	MK4	4	175	70	31,267	223,05	105	120,55	60°	0,005
S605-100	MK5	5	100	25	44,399	221,10	77	91,60	60°	0,005
S605-125	MK5	5	125	35	44,399	227,10	83	97,60	60°	0,005
S605-150	MK5	5	150	50	44,399	240,05	95	110,55	60°	0,005
S606-175	MK6	6	175	70	63,348	305	105	122,00	60°	0,010

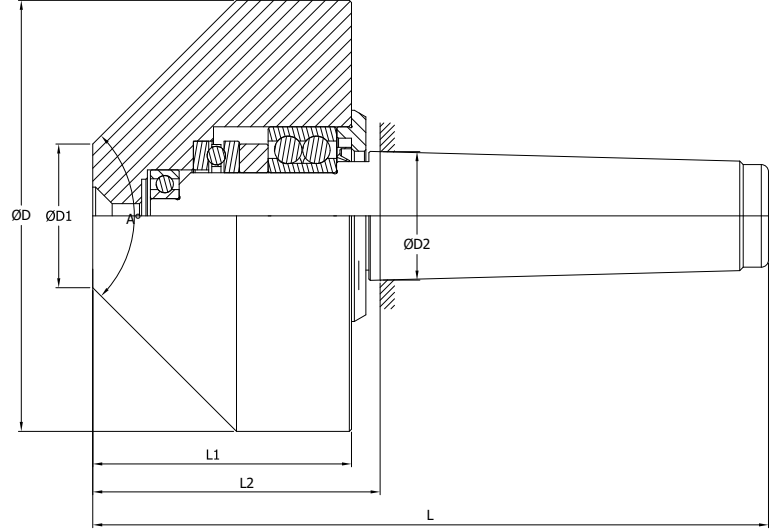

TR

- Çelik gövde
- Yüksek hassasiyet
- Yüksek salgı hassasiyeti

EN

- Steel body
- High precision
- High concentricity precision



tuma.com.tr

Sipariş Kodu / Order Code	Tip / Type	Mors Koniği / Mors Taper	Ölçüler / Dimensions							Uç Salgısı / Center Runout
			D	D1	D2	L	L1	L2	A°	
S624-150	MK4	4	150	50	31,267	208,05	90	105,55	90°	0,005
S624-175	MK4	4	175	50	31,267	211,05	93	108,55	90°	0,005
S624-200	MK4	4	200	50	31,267	211,05	93	108,55	90°	0,005
S625-150	MK5	5	150	50	44,399	235,05	90	105,55	90°	0,005
S625-175	MK5	5	175	50	44,399	238,05	93	108,55	90°	0,005
S625-200	MK5	5	200	50	44,399	238,05	93	108,55	90°	0,005
S625-250	MK5	5	250	75	44,399	275,00	130	145,40	90°	0,005
S626-150	MK6	6	150	50	63,348	290,00	90	107,31	90°	0,010
S626-175	MK6	6	175	50	63,348	293,00	93	110,31	90°	0,010
S626-200	MK6	6	200	50	63,348	293,00	93	111,00	90°	0,010
S626-250	MK6	6	250	75	63,348	330,50	130	148,50	90°	0,010

DEĞİŞEBİLİR UÇLU DÖNER PUNTALAR (D-500)

CNC ROTARY CENTERS WITH CHANGEABLE TIPS (D-500)

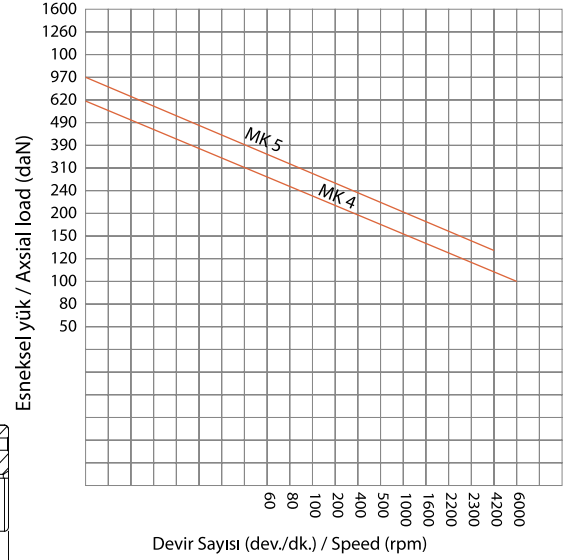
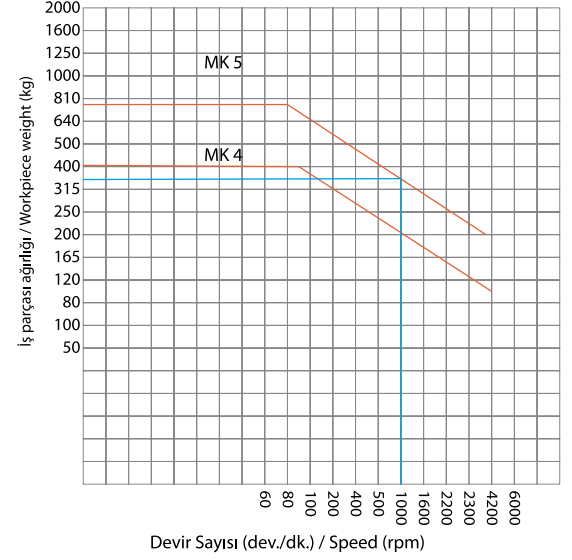
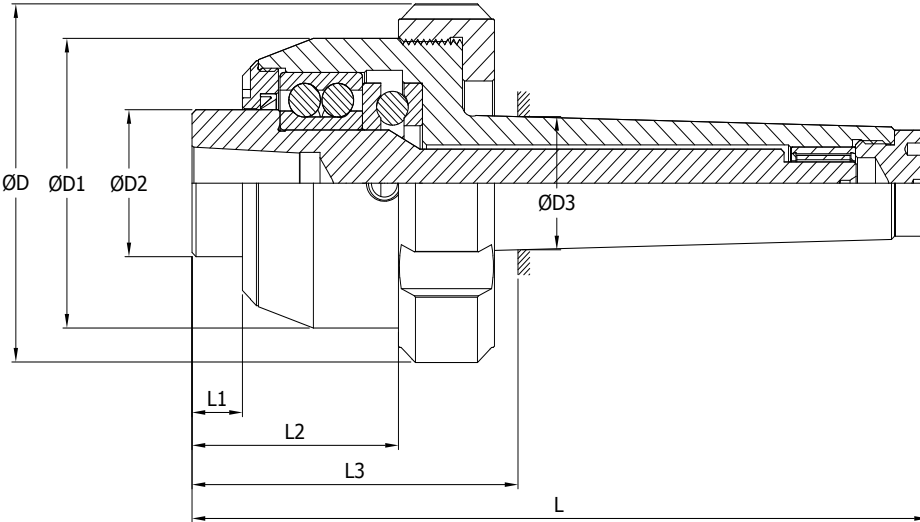

tuma.com.tr

Sipariş Kodu / Order Code	Tip / Type	Mors Koniği / Mors Taper	Ölçüler / Dimensions								Uç Salgısı / Center Runout
			D	D1	D2	D3	L	L1	L2	L3	
D504-00	D-500	4	85	68	34,50	31,267	183,84	12,60	51,60	81,34	0,005
D505-00	D-500	5	85	68	34,50	44,399	226,39	12,60	66,60	96,89	0,005

NO-1

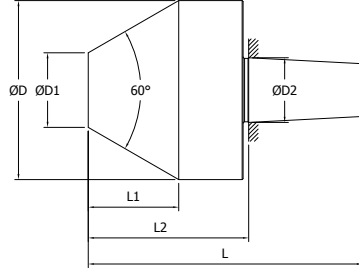

Sipariş Kodu / Order Code	Mors Koniği / Mors Taper	Ölçüler / Dimensions						Uç Salgısı / Center Runout
		D	D1	D2	L	L1	L2	
D504-01	4	48	20	17	73,50	24,25	46,27	0,005
D505-01	5	58	30	17	70	24,25	42,77	0,005

NO-2

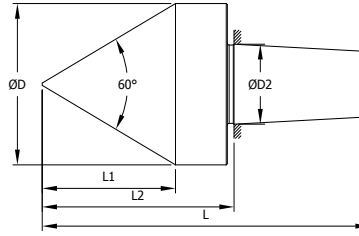

Sipariş Kodu / Order Code	Mors Koniği / Mors Taper	Ölçüler / Dimensions					Uç Salgısı / Center Runout
		D	D2	L	L1	L2	
D504-02	4	35	17	73,50	29,80	46,27	0,005
D505-02	5	44	17	85	37,67	57,77	0,005

NO-3

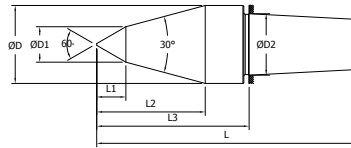

Sipariş Kodu / Order Code	Mors Koniği / Mors Taper	Ölçüler / Dimensions							Uç Salgısı / Center Runout
		D	D1	D2	L	L1	L2	L3	
D504-03	4	22	10	17	73,50	8,23	30,62	46,27	0,005
D505-03	5	30	14	17	85	11,69	41,55	57,77	0,005

NO-4

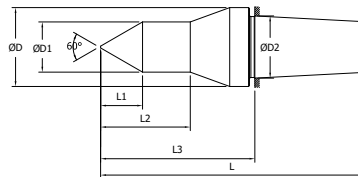

Sipariş Kodu / Order Code	Mors Koniği / Mors Taper	Ölçüler / Dimensions							Uç Salgısı / Center Runout
		D	D1	D2	L	L1	L2	L3	
D504-04	4	22	14	17	73,50	11,69	25	46,27	0,005
D505-04	5	30	20	17	85	16,89	30	57,77	0,005

NO-5

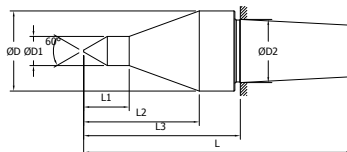

Sipariş Kodu / Order Code	Mors Koniği / Mors Taper	Ölçüler / Dimensions							Uç Salgısı / Center Runout
		D	D1	D2	L	L1	L2	L3	
D504-05	4	22	8	17	73,50	12,50	31,73	43	0,005
D505-05	5	30	10	17	85	15	42,47	57,77	0,005

MAKİNA
MENGENE



TUMA[®]
HASSAS TUTUCU TAKIMLAR

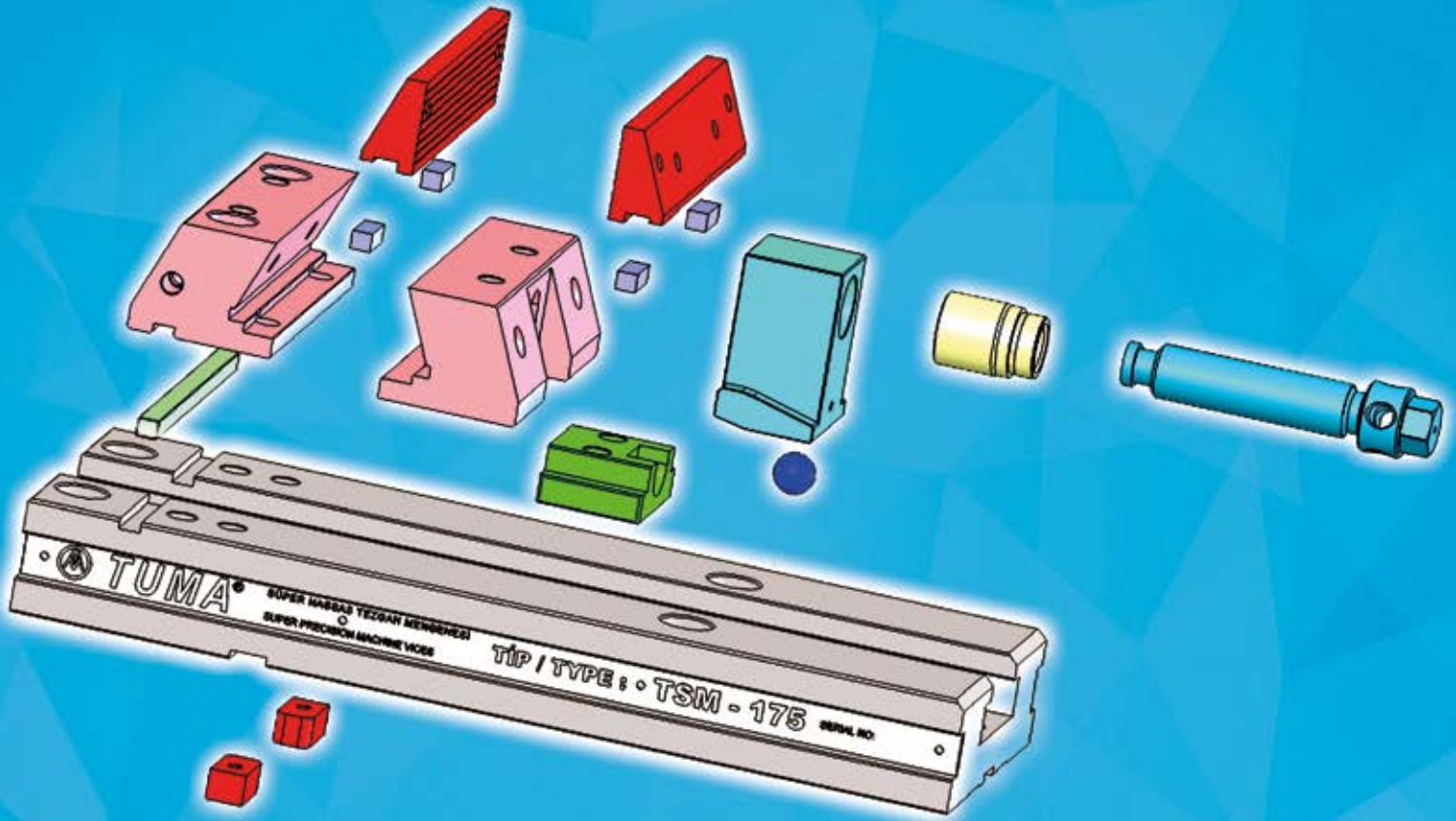

MACHINE VICES

TR

- Sementasyonla sertleştirilmiş çelik gövde ve çeneler
- Hareketli yüzeylerin tamamı hassas taşlanmıştır
- Gövdeler arası düzlemsellik farkı max 0.025 mm'dir
- 0.02 mm'nin altında paralellik toleransı
- Mekanik ve hidrolik sıkma üniteleri birbiri ile değiştirilebilir
- Hareketli çenenin gövde üzerinde boşluklu ya da boşluksuz çalışması ayarlanabilir

EN

- Case hardened steel body and jaws
- Precision grinding is made to all sliding surfaces
- Planeness difference between the guide ways are less than 0.025mm
- Parallelism tolerance is less than 0.02 mm
- Interchangeable mechanical and hydraulic clamping units
- Quick stroke adjusting
- The sliding jaw has a tilting effect which allows clamping asymmetrical parts or it can be fixed

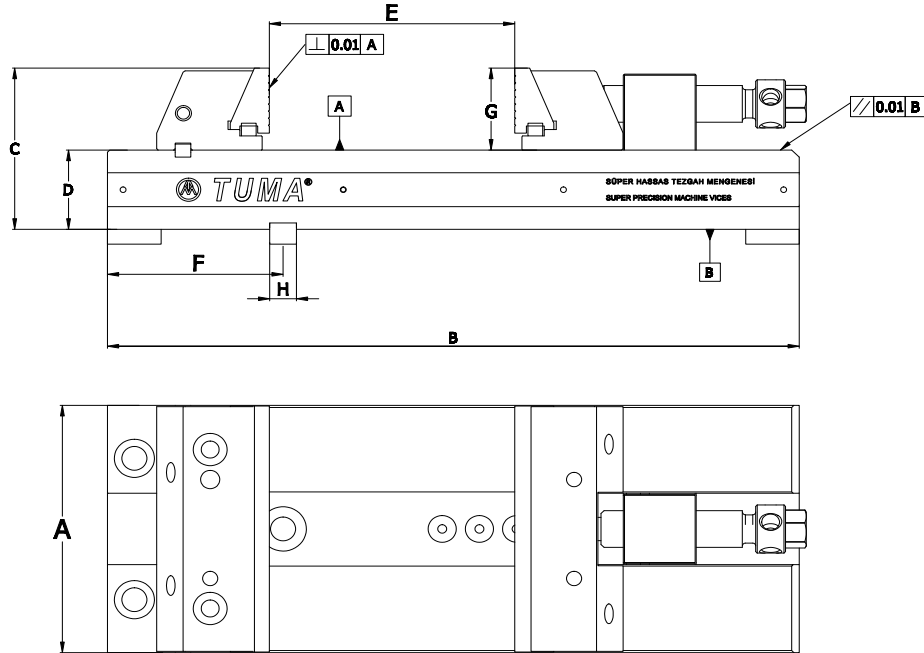

tuma.com.tr

Sipariş Kodu / Order Code	Tip / Type	Mors Koniği / Mors Taper	Ölçüler / Dimensions					
			A	B	C	D	E (Max.)	F
TSM-125	125	125	335	80	40	0-130	-	40
TSM-150	150	150	423	105	51	0-200	132	55
TSM-175	175	175	540	112	56	0-300	118	58
TSM-200	200	200	540	125	61	0-300	118	66

CNC TORNA ÇUBUK ÇEKİCİ

CNC LATHE BAR PULLERS

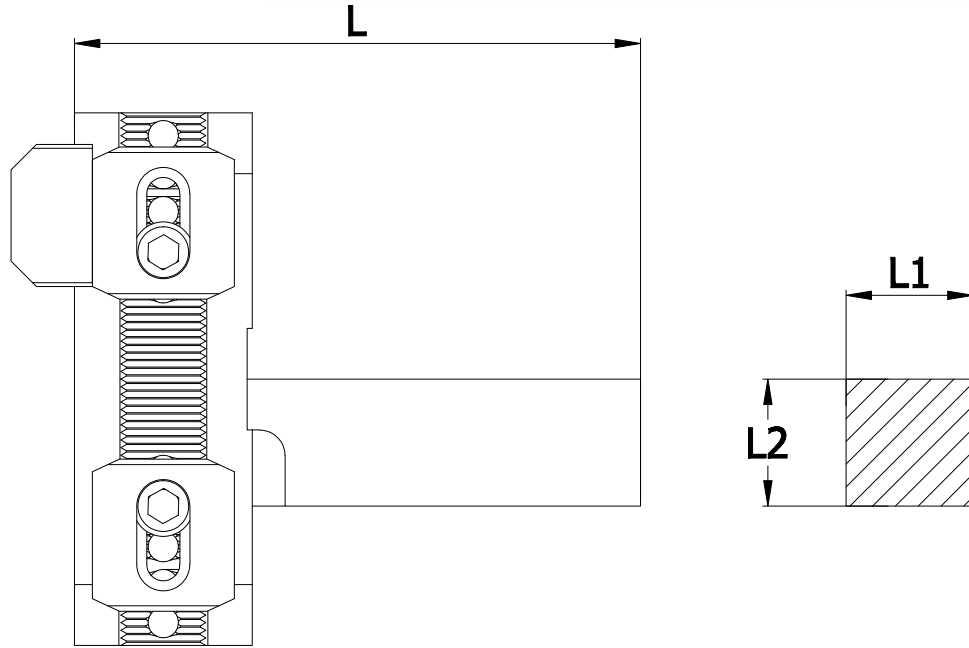

tuma.com.tr

Sipariş Kodu / Order Code	Ölçüler / Dimensions			
	L	L1	L2	Dmin./Dmax.
CNC-CC-20	103,50	20	20	MİN5-MAX0,70
CNC-CC-25	111,50	25	25	MİN5-MAX0,70



• Alışılmış çelikten üretilmiş olup, komple yüzeyi taşlanmıştır ^{TR}

• Produced from alloyed steel and all surfaces are grinded ^{EN}

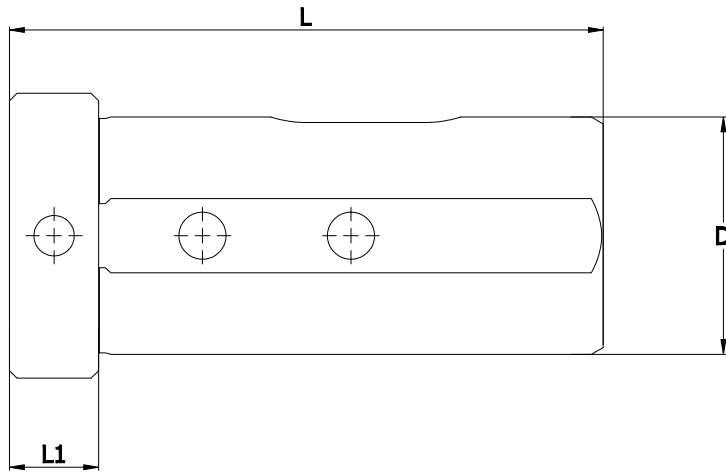
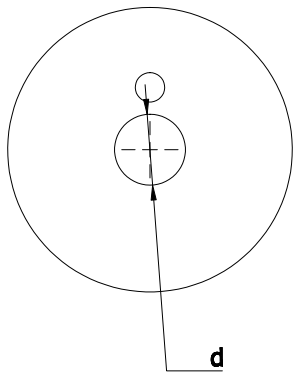

tuma.com.tr

Sipariş Kodu / Order Code	Tip / Type	Ölçüler / Dimensions		
		D	D1	L
CNC-SS-RK-32-8	32	8	90	75
CNC-SS-RK-32-10	32	10	90	75
CNC-SS-RK-32-12	32	12	90	75
CNC-SS-RK-32-16	32	16	90	75
CNC-SS-RK-32-20	32	20	90	75
CNC-SS-RK-32-25	32	25	90	75

Sipariş Kodu / Order Code	Tip / Type	Ölçüler / Dimensions		
		D	D1	L
CNC-SS-RK-40-8	40	8	100	85
CNC-SS-RK-40-10	40	10	100	85
CNC-SS-RK-40-12	40	12	100	85
CNC-SS-RK-40-16	40	16	100	85
CNC-SS-RK-40-20	40	20	100	85
CNC-SS-RK-40-25	40	25	100	85
CNC-SS-RK-40-32	40	32	100	85

SABİT PUNTALAR (S-400)

FIXED LATHE CENTERS (S-400)

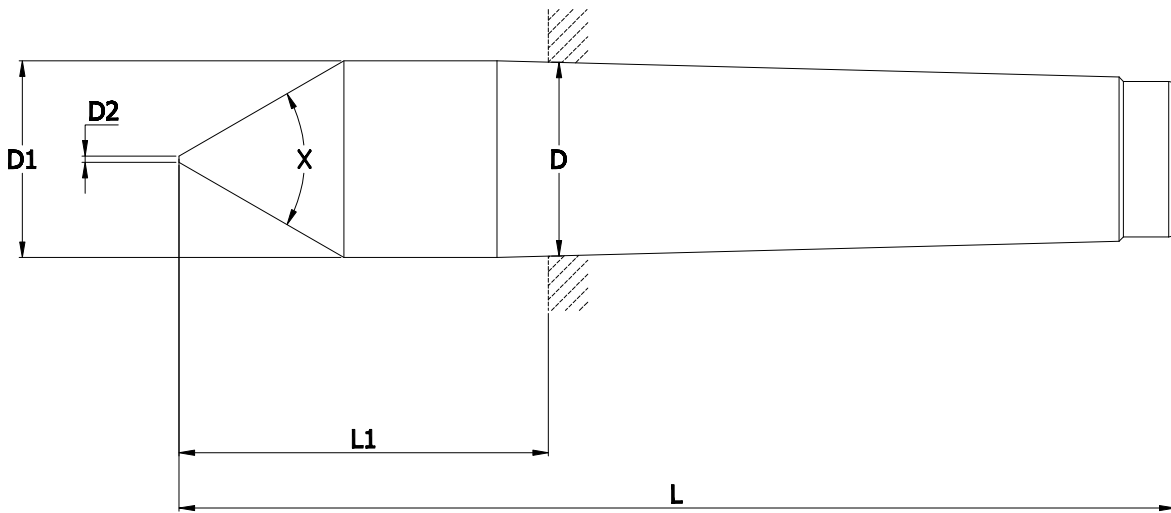

tuma.com.tr

Sipariş Kodu / Order Code	Tip / Type	Ölçüler / Dimensions						Uç Salgısı / Center Runout
		D	D1	D2	L	L1	X°	
S-402	MK2	17,78	18	0,80	100	36	60°	0,005
S-403	MK3	23,825	24,10	0,80	125	44	60°	0,005
S-404	MK4	31,267	31,60	1,00	160	57,50	60°	0,005
S-405	MK5	44,399	44,70	1,60	200	70,50	60°	0,005
S-406	MK6	63,348	63,80	1,50	270	88	60°	0,005



KESİK UÇLU SABİT PUNTALAR (S-410)

HALF POINT FIXED LATHE CENTERS (S-410)

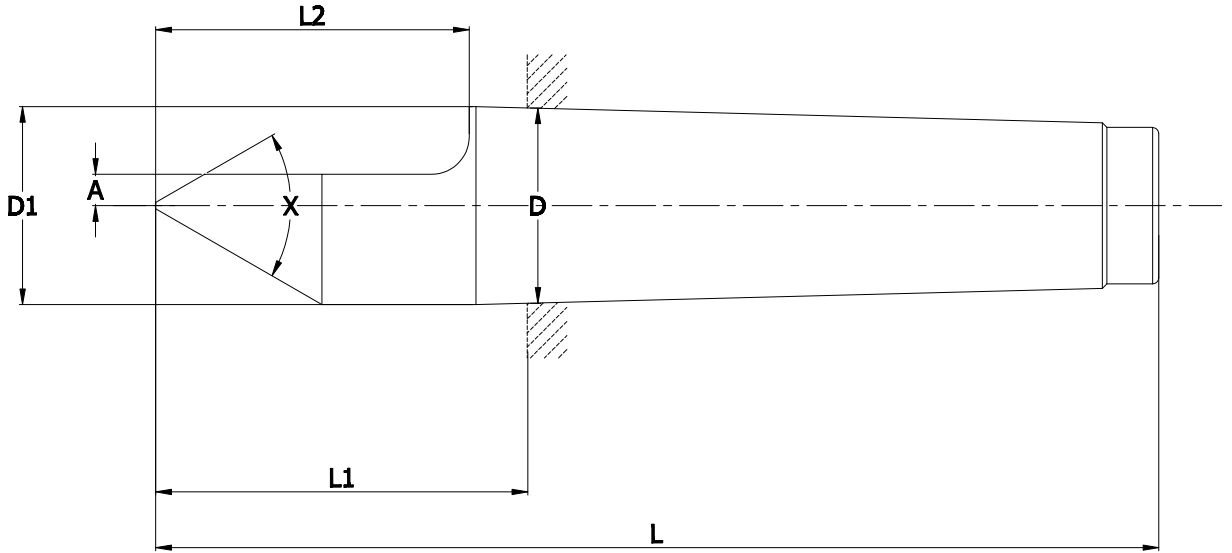

tuma.com.tr

Sipariş Kodu / Order Code	Tip / Type	Mors Koniği / Mors Taper	Ölçüler / Dimensions								Uç Salgısı / Center Runout
			D	D1	D2	L	L1	L2	A	X°	
S-412	MK2	2	17,78	18	0,80	100	36	30	2	60°	0,005
S-413	MK3	3	23,825	24,10	0,80	125	44	38	3	60°	0,005
S-414	MK4	4	31,267	31,60	1,00	160	57,50	50	5	60°	0,005
S-415	MK5	5	44,399	44,70	1,60	200	70,50	63	7	60°	0,005
S-416	MK6	6	63,348	63,80	1,50	270	88	79	10	60°	0,005

KARBÜR UÇLU SABİT PUNTALAR (S-420)

FIXED LATHE CENTERS WITH CARBIDE TIP (S-420)



- TR
- Çelik gövde
 - Karbür uç

- EN
- Steel body
 - Carbide tip

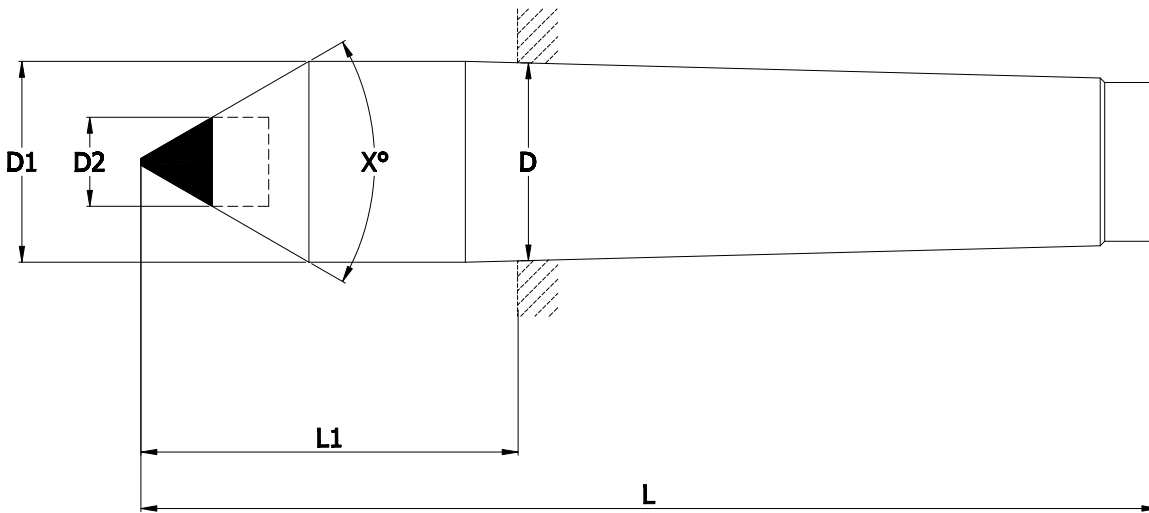

tuma.com.tr

Sipariş Kodu / Order Code	Tip/Type	Ölçüler / Dimensions						Uç Salgısı / Center Runout
		D	D1	D2	L	L1	X°	
S-422	MK2	17,78	18	7	100	36	60°	0,005
S-423	MK3	23,825	24,10	11	125	44	60°	0,005
S-424	MK4	31,267	31,60	14	160	57,50	60°	0,005
S-425	MK5	44,399	44,70	18	200	70,50	60°	0,005
S-426	MK6	63,348	63,80	18,70	270	88	60°	0,005



SERT MADEN UÇLU KESİK PUNTALAR (S-430)

HALF FIXED LATHE CENTERS WITH CARBIDE TIP (S-430)

- TR
- Çelik gövde
 - Karbür uç

- EN
- Steel body
 - Carbide tip

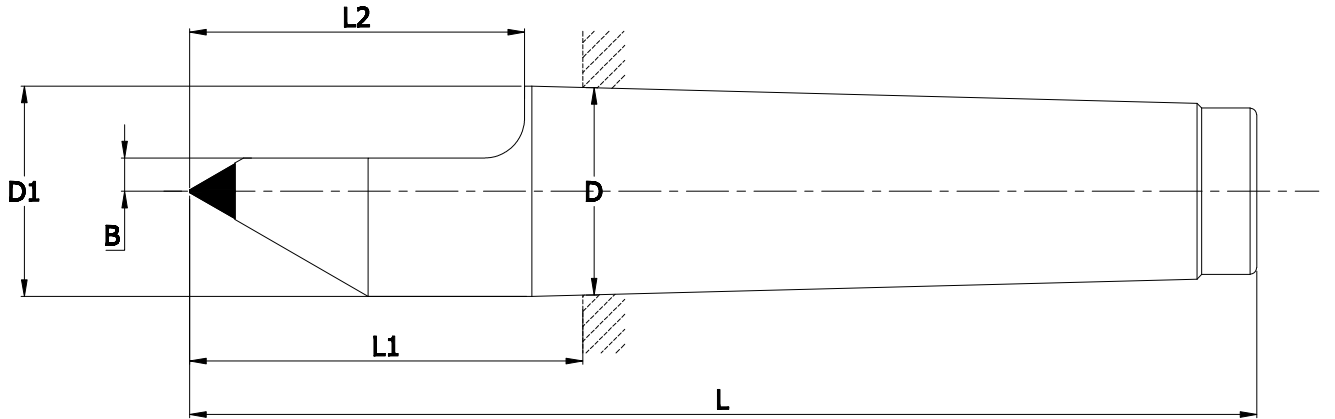

tuma.com.tr

Sipariş Kodu / Order Code	Tip / Type	Mors Koniği / Mors Taper	Ölçüler / Dimensions							Uç Salgısı / Center Runout
			D	D1	L	L1	L2	B	X°	
S-432	MK2	2	17,78	18	100	36	30	2	60°	0,005
S-433	MK3	3	23,825	24,10	125	44	38	3	60°	0,005
S-434	MK4	4	31,267	31,60	160	57,50	50	5	60°	0,005
S-435	MK5	5	44,399	44,70	200	70,50	63	7	60°	0,005
S-436	MK6	6	63,348	63,80	270	88	79	10	60°	0,005

SOMUNLU SABİT PUNTALAR (SS400)

FIXED CENTERS WITH NUT (SS400)

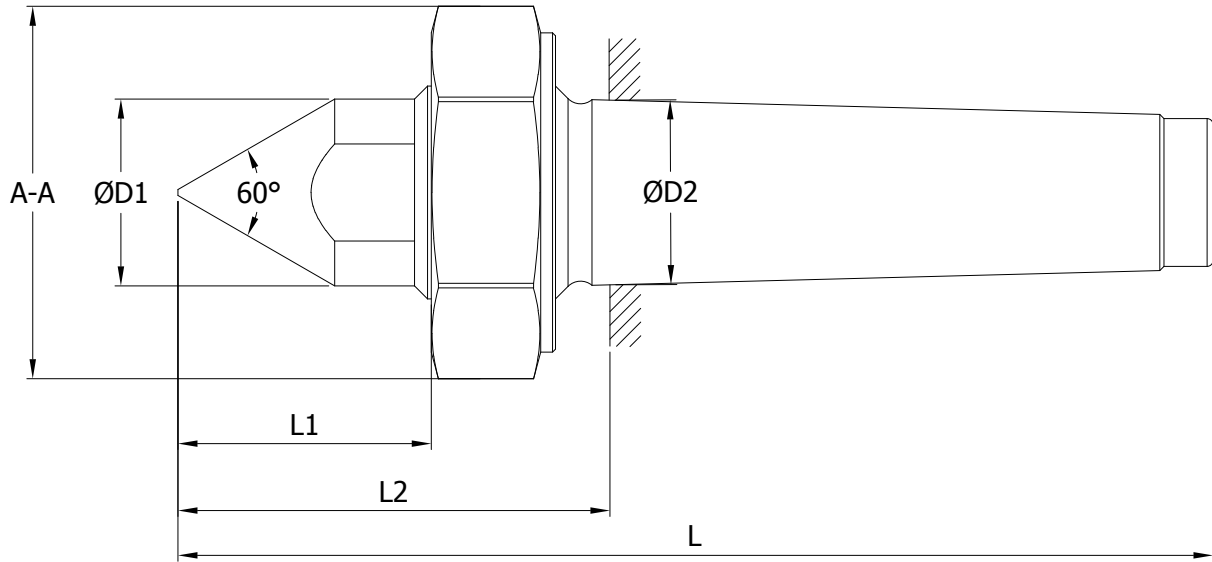

tuma.com.tr

Sipariş Kodu / Order Code	Tip / Type	Mors Koniği / Mors Taper	Ölçüler / Dimensions						Uç Salgısı / Center Runout
			D	D1	D2	L	L1	L2	
SS-403	MK3	3	41	24,10	23,825	138	32,46	57	0,005
SS-404	MK4	4	55	31,60	31,267	175	42,83	72,50	0,005
SS-405	MK5	5	75	44,70	44,399	217	54,932	87,50	0,005
SS-406	MK6	6	100	63,80	63,348	290	71,70	108	0,005



SOMUNLU SABİT PUNTALAR (SS420)

FIXED CENTERS WITH NUT (SS420)

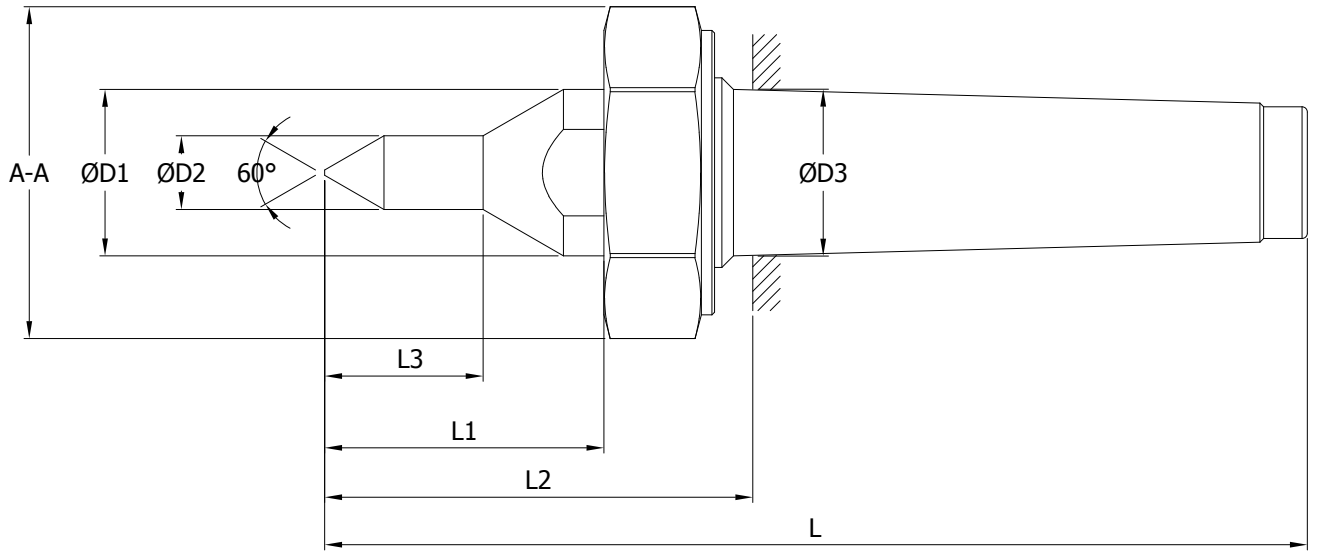

tuma.com.tr

Sipariş Kodu / Order Code	Tip / Type	Mors Koniği / Mors Taper	Ölçüler / Dimensions								Uç Salgısı / Center Runout
			AA	D1	D2	D3	L	L1	L2	L3	
SS-423	MK3	3	41	24,10	10	23,825	148	41,45	67	20	0,005
SS-424	MK4	4	55	31,60	14	31,267	186,50	53,70	84	30	0,005
SS-425	MK5	5	75	44,70	16	44,399	242	78,25	112,50	32	0,005
SS-426	MK6	6	100	63,80	18	63,348	340	121,70	158	45	0,005

SOMUNLU SABİT PUNTALAR (SS410)

FIXED CENTERS WITH NUT (SS410)

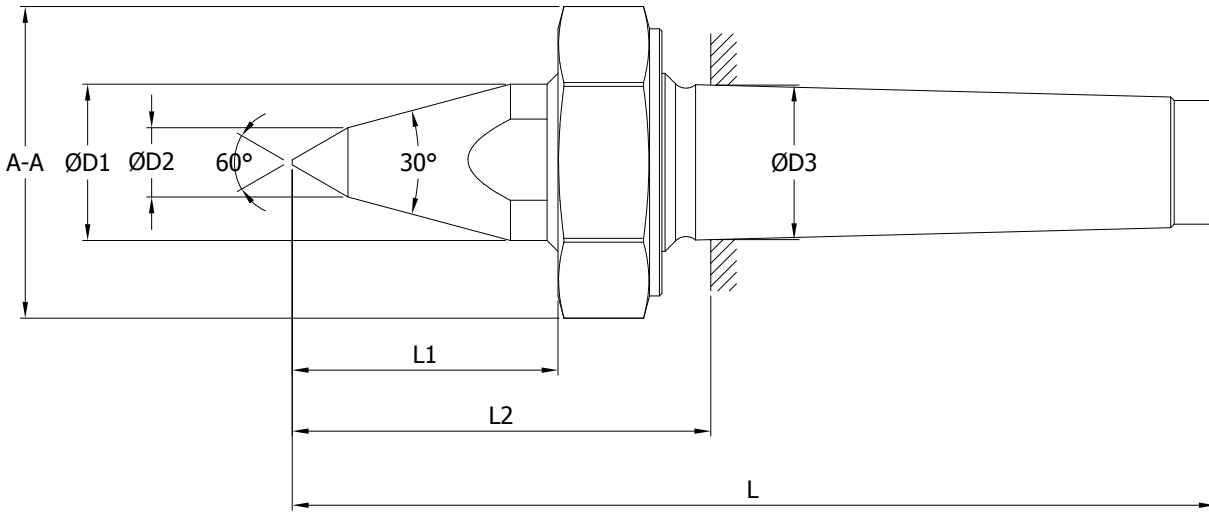

tuma.com.tr

Sipariş Kodu / Order Code	Tip / Type	Mors Koniği / Mors Taper	Ölçüler / Dimensions							Uç Salgısı / Center Runout
			A-A	D	D1	D2	L	L1	L2	
SS-413	MK3	3	41	24,10	10	23,825	148	41,45	67	0,005
SS-414	MK4	4	55	31,60	14	31,267	186,50	53,70	84	0,005
SS-415	MK5	5	75	44,70	16	44,399	242	78,25	112,50	0,005
SS-416	MK6	6	100	63,80	18	63,348	340	121,70	158	0,005



 	KALİTE YÖNETİM SİSTEMİ BELGESİ QUALITY MANAGEMENT SYSTEM CERTIFICATE	Partner of 										
<p>TÜRK STANDARLARI ENSTİTÜSÜ bu belge ile</p> <p>TUMA HASSAS TUTUCU TAKIMLARI MEDİKAL OTOMOTİV MAKİNA SAN. VE TİC. LTD. ŞTİ. FEVZİ ÇAKMAK MAH. BÜSAN ORG. SAN. MİLENYUM CAD. NO:19F KARATAY - KONYA / TÜRKİYE</p> <p>Kuruluşun TS EN ISO 9001:2015 şartlarına uygun bir KALİTE YÖNETİM SİSTEMİNE sahip olduğunu beyler.</p> <p>Belge kapsamı Ek'ye verilmiştir</p>	 <p>TÜRK STANDARLARI ENSTİTÜSÜ TURKISH STANDARDS INSTITUTION</p> <p>SİSTEM BELGELERİNDEN GRUPO BASKANI HEAD of SYSTEM CERTIFICATION GROUP</p> <p><i>Gökcen Bircan Değerli</i> GÖNCEN BİRCAN DEĞERLİ</p> <p><small>Türk Standartları Enstitüsü Türk Akademi Kurumu TÜRKAK (certification akreditasyonu) Turkish Standards Institution, has been accredited by the Turkish Accreditation Agency, TÜRKAK.</small></p>	<p>TURKISH STANDARDS INSTITUTION hereby certifies that the organization</p> <p>TUMA HASSAS TUTUCU TAKIMLARI MEDİKAL OTOMOTİV MAKİNA SAN. VE TİC. LTD. ŞTİ. FEVZİ ÇAKMAK MAH. BÜSAN ORG. SAN. MİLENYUM CAD. NO:19F KARATAY - KONYA / TÜRKİYE</p> <p>has a QUALITY MANAGEMENT SYSTEM which fulfills the requirements of the TS EN ISO 9001:2015</p> <p>Scope of the certificate is given in annex</p> <table border="1"><tr><td>Belge No / Certificate No</td><td>KY-9997/136-R15</td></tr><tr><td>Belge Tarihi / Date of Certificate</td><td>21.12.2017</td></tr><tr><td>Geçerlilik Tarihi / Valid Until</td><td>20.12.2019</td></tr><tr><td>Revizyon Tarihi / Date of Revision</td><td>21.12.2017</td></tr><tr><td>Bu Belge Tarihi / Initial Certification Date</td><td>21.01.2016</td></tr></table> <p><small>The holder of this product has committed with the certification requirement is maintained.</small></p>	Belge No / Certificate No	KY-9997/136-R15	Belge Tarihi / Date of Certificate	21.12.2017	Geçerlilik Tarihi / Valid Until	20.12.2019	Revizyon Tarihi / Date of Revision	21.12.2017	Bu Belge Tarihi / Initial Certification Date	21.01.2016
Belge No / Certificate No	KY-9997/136-R15											
Belge Tarihi / Date of Certificate	21.12.2017											
Geçerlilik Tarihi / Valid Until	20.12.2019											
Revizyon Tarihi / Date of Revision	21.12.2017											
Bu Belge Tarihi / Initial Certification Date	21.01.2016											

062112201706190001

 	KALİTE YÖNETİM SİSTEMİ BELGESİ QUALITY MANAGEMENT SYSTEM CERTIFICATE EK / APPENDIX	Partner of 
<p>Belge No / Certificate No: KY-9997/136-R15</p> <p>Belge Kuruluş Adı, Adresi: Name and Address of the Certified Organization:</p> <p>Belge Kapsamı: TS EN ISO 9001:2015 HASSAS TUTUCU TAKIM İMALATI VE SATIŞI</p>	 <p>TÜRK STANDARLARI ENSTİTÜSÜ TURKISH STANDARDS INSTITUTION</p>	<p>Belge Tarihi / Date of Certificate: 21.12.2017</p> <p>TUMA HASSAS TUTUCU TAKIMLARI MEDİKAL OTOMOTİV MAKİNA SAN. VE TİC. LTD. ŞTİ. FEVZİ ÇAKMAK MAH. BÜSAN ORG. SAN. MİLENYUM CAD. NO:19F KARATAY - KONYA / TÜRKİYE</p> <p>Scope of the Certificate: TS EN ISO 9001:2015 MANUFACTURING AND SALES OF PRECISION CHUCKING TOOLS</p>

062112201706190001



Alex Stoichitoiu
Alex Stoichitoiu
President of IQNet

Gökten Bircan Değerişir
Gökten Bircan Değerişir
Head of System Certification Group



KALİTE POLİTİKAMIZ

TUMA HASSAS TUTUCU TAKIMLAR San. ve Tic.Ltd. Şti.; “TUMA” markasını “Kalite”, “Teknoloji” ve “Güven” kavramları ile özdeş hale getirmek suretiyle, müşteri talep ve beklentileri doğrultusunda yasal ve mevzuat şartlarına uygun; Kalite Yönetim Sistemi ilkelerine bağlı hizmet vermeyi kuruluş amacı olarak benimsemiştir. Bütün çalışanlarımız bu bilinçle, yapmış olduğu işi “ilk seferinde ve hatasız” yapması, yanlışlıklardan doğan kayıpların önlenmesi ve verimliliğin artırılması yönünde eğitilmektedir.

Çalışanlarımızın teknik, sosyal ve kültürel açıdan sürekli gelişiminin sağlanması sistemimizin bir parçasıdır. Üretim sistemlerinde yüksek kalite, düşük maliyet, esnek üretim ve zamanında teslimata ulaşmak firmamızın öncelikli görevidir. Bununla birlikte tedarikçilerimizin de bizimle aynı kalitede mal ve hizmet üretmesini sağlamak için bilgilendirilmesi ve teknik eksikliklerinin giderilmesi çabalarımız içerisindedir. En özgün karakterimiz, müşteri ihtiyaçlarına uygun ve onların beklentilerinin üzerinde üretim yapmaktır. Bunun yanı sıra, müşteri memnuniyeti, güvenlik, insana ve doğaya saygılı üretim ve üretkenlik de bizim için vazgeçilmezdir.

Yenilikçi, dürüst ve günümüzün kalite kavramına uygun yönetim anlayışımızla her gün daha büyük başarılarla imza atmaktayız.



OUR QUALITY POLICY

TUMA HASSAS TUTUCU TAKIMLAR SAN. VE TİC. LTD. ŞTİ (TUMA PRECISION CNC WORKHOLD-ING TOOLS COMPANY) made its "TUMA" brand memorized with "Quality", "Technology" and "Trust" through the expectations and demands of customers according to laws and regulations as the founding aim with principles of Quality Management Systems. All of our staffs are trained with this knowledge to make all products "at the first time with no mistake" and increase productivity and prevent loss caused by production faults.

It is a part of our systems to ensure technical, social and cultural improvements of our staffs. Achieving to high quality with less cost, flexible production and delivery on time are main duties of our company.

We also make our raw material suppliers improve their knowledge and be aware of their technical shortage to produce high quality products and give good service like ours.

The most original characteristic of us is making production according to needs of our customers and even higher quality production than expectations of our customers. Furthermore, customer satisfaction, safety, production respecting human being and nature and productivity are indispensable for us.

We achieve greater successes everyday by innovative, honest sense of rule appropriate to today's quality.

Precision of our products is very high. Concentricity of our products is very less. We produce our products from steel. But, we can also produce from casting upon demand of our customers.

